

USER MANUAL

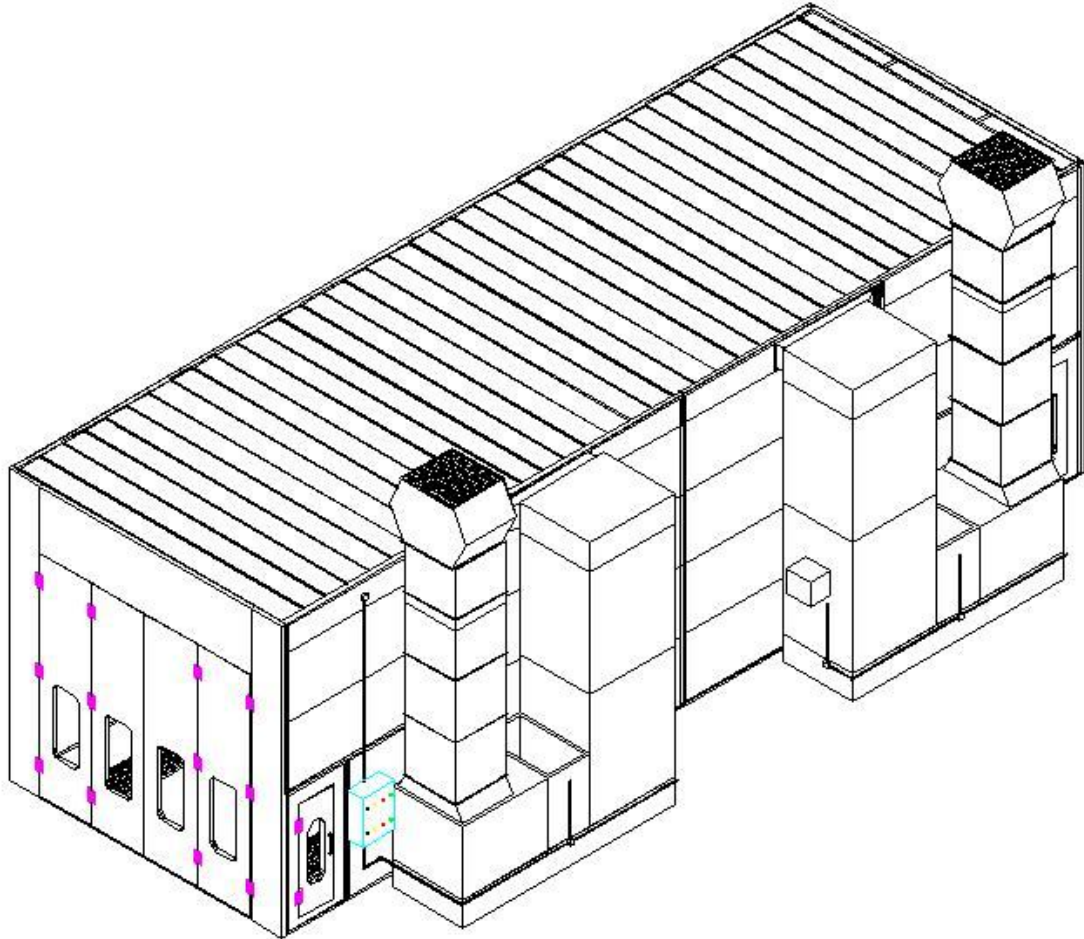

**Guangli Spray Booth
Model: GL10**

Contents

CHAPTER 1 SPRAY BOOTH DESCRIPTION	- 1 -
1.1 THE STRUCTION DESCRIPTION	- 1 -
1.1.1 THE MAIN ROOM	- 2 -
1.1.2 GENERATOR PART	- 5 -
1.1.3 CONTROL PANEL.....	- 7 -
1.1.4 SOME OPTIONAL PARTS.....	- 9 -
1.2 THE PRINCIPLE OF THE SPRAY BOOTH.....	- 10 -
1.2.1 SPRAY PAINTING PHASE.....	- 10 -
1.2.2 DRYING PHASE	- 11 -
1.3 TECHNICAL PARAMETER DIFFERENCE	- 12 -
CHAPTER 2 THE INSTALLATION OF THE SPRAY BOOTH	- 13 -
2.1 THE INSTALLATION ENVIRONMENTAL CHARACTERISTICS	- 13 -
2.2 SOME NECESSARY TOOLS	- 14 -
2.3 INSTALLATION METHODS AND STEPS	- 14 -
2.3.1 Basement installation	- 14 -
2.3.2 Main room fram installation	- 15 -
2.3.4 Ceiling Installation	- 19 -
2.3.2 Generator Installation.....	- 22 -
2.4 Control System Installation	- 25 -
CHAPTER 3 TEST AND OPERATION	- 29 -
3.1 PREPARATION BEFORE.....	- 29 -
3.1.1 PREPARATION BEFORE TESTING AND OPERATION	- 29 -
3.1.2 ATTENTION BEFORE TESTING AND OPERATION.....	- 29 -
3.1.3 TEST THE ROTATION OF THE BLOWER	- 29 -
3.1.4TEST THE DAMPER SYSTEM	- 29 -
3.2 ATTENTION NORMS.....	- 29 -
3.3 OPERATION.....	- 30 -
3.3.1 PAINTING STATION.....	- 30 -
3.3.2 DRYING STATION	- 31 -
3.3.3 MACHINE STOP.....	- 31 -
CHAPTER 4 MAINTENANCE AND REPAIR	- 32 -
4.1 ORDINARY MAINTENANCE.....	- 32 -



SPRAY BOOTH SPECIFICATION

4.2 ORDINARY MAINTENANCE INSTRUCTION	- 32 -
4.3 SOME SPARE PARTS FOR MAINTENANCE	- 33 -
CHAPTER 5 PACKING,SHIPPING AND STORAGE	- 34 -
5.1 PACKING.....	- 34 -
5.2 SHIPPING.....	- 34 -
5.3 STORAGE	- 35 -
APPENDIX I : MALFUNCTION AND REMEDY	- 36 -
APPENDIX III : ELECTRICAL CHART(SHOWN IN ATTACHED FILE)	- 37 -
APPENDIX IV : STRUCTRUE OF THE BOOTH(SHOWN IN ATTACHED FILE).....	- 37 -

Chapter 1 Spray Booth Description

1.1 The Struction Description

The spray booth is composed of the following parts:(shown in Fig.1.1)

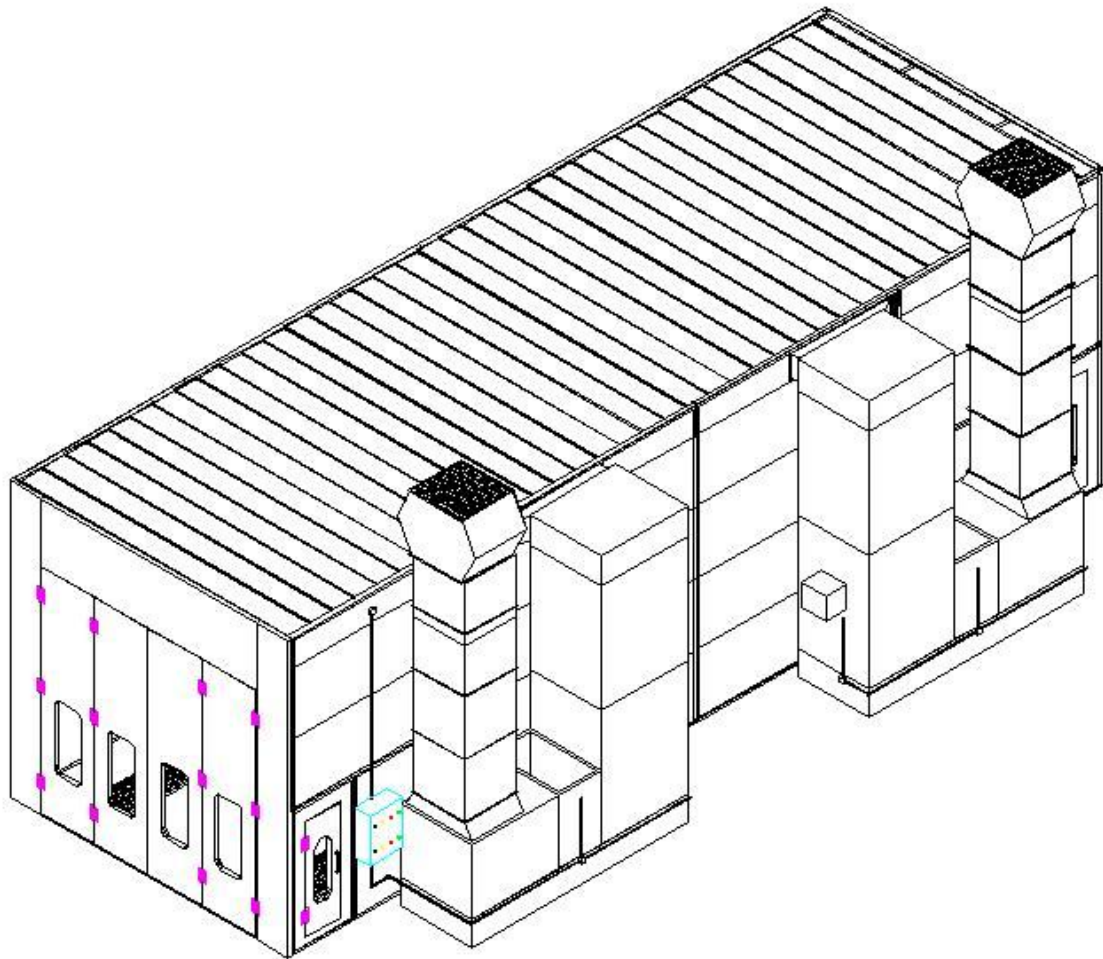

Fig. 1.1

- 1) The main room:
 - The base parts: Floor grids, floor filter and filter supporting frame.
 - The body parts: wall board with or without side light, front door with (including horizontal board and stand board), safe door, surround pieces of wall board ect.
 - The top parts(air cabinet) : top sealed board, lighting frame, filter slot panel, supporting for the filter, roof supporter beam, filter, roof cover.
- 2) Generator parts(Two sets)
 - Bottom of heat-air generator
 - Middle frame of generator :including the intake fansr and heat exchanger
 - Burner, diesel burn for standard model and gas burner for optional.
 - Top-frame for generator、 the connection part between top frame and air cabinet

- Damper for change between painting and baking system.
 - VCD adjust damper, which can adjust the air capacity between intake and exhaust air.
 - Exhaust system: exhaust fan with pre-filter, Active carbon environment system as option
 - Smoke tube: connect with heat-exchanger, take the heat out.
 - Air duct: exhaust duct is necessary and intake duct as option.
- 3) Oil tank with frame
- 4) Control system: control the motor, burner, light system ect.

1.1.1 The Main Room

The spray painting environment is the closed place when the spray painting and the drying process is carried out. it is divided into the following parts:

1) Side walls

The side walls are necessary to isolate the spray painting environment from the outside, both from the thermal and acoustic point of view, and above all so as not to disperse the paint and solvents residue into the environment, it is formed by: (shown in Fig.1.2)

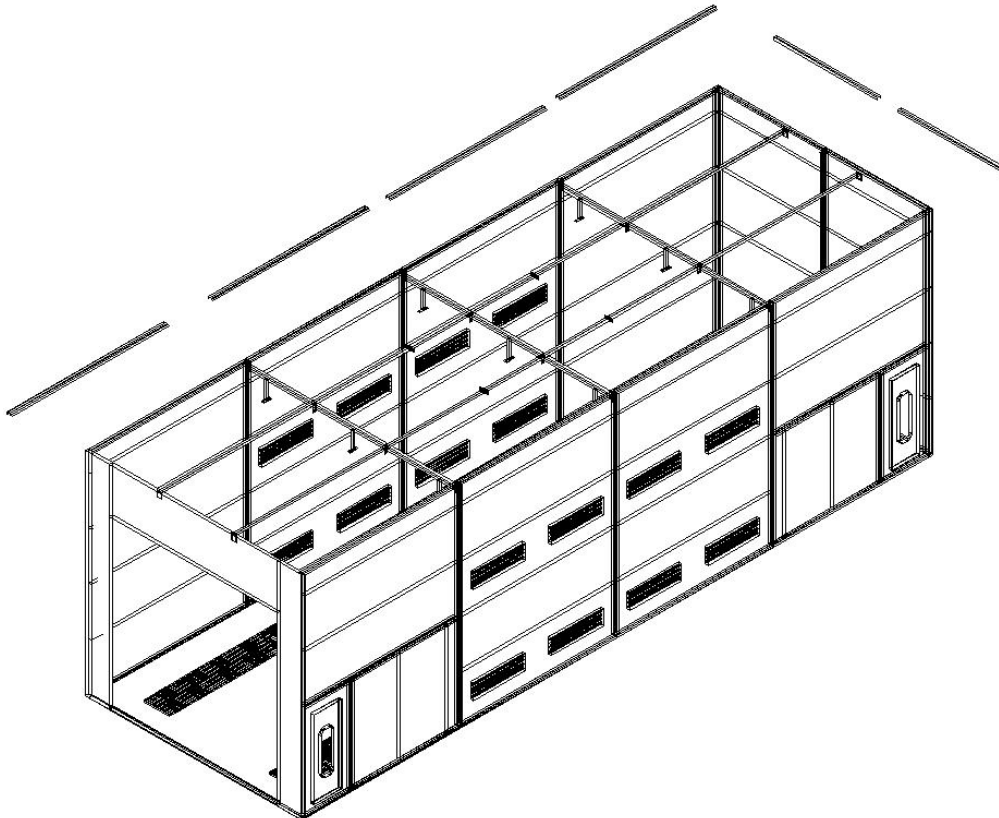

Fig 1.2

- Side walls made of panels, with a thickness of 75 mm, modular types with tongue and groove jointed, inserts with added seals. The thermal insulation of the spray painting environment is warranted by the layer of expanded polyurethane or rock wool contained in the panels.
- Back walls, panels made of the same type as the side walls.

- Metal covers up the wall, are necessary for the up cover of the walls, which make each panel connect together and easy to install the ceiling cover.
- Back corners, that are necessary for the connection between the side walls and the back wall.

2) Front walls

The front wall of the booth is composed of : (shown in Fig.1.3)

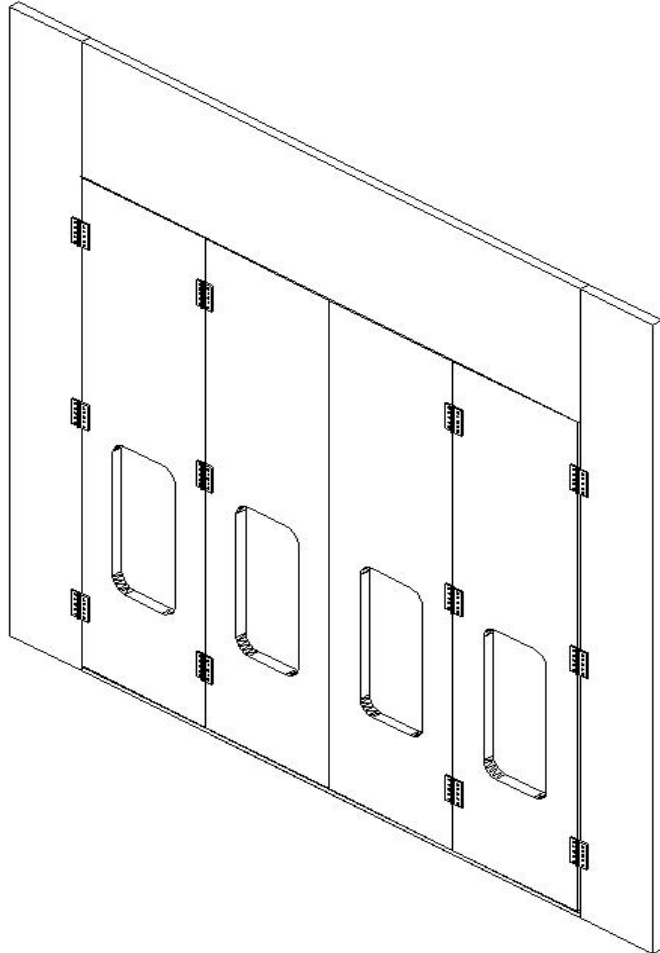

Fig. 1.3

- The header horizontal panel, is necessary for the plenum chamber and as a closure of the head part of the front wall.
- Maid door with the glass window, for the entry-exit of the operator, equipped with a spring release opening.
- Side erect panel, is necessary to support the maid door and connect to the side wall panel.
- The installed fitting parts: such as the door lock, handle, hinges, connection bar for horizontal panel and erect panel.

3) Illumination system

- The internal illumination is warranted by the overhead lights (shown in Fig.1.4) inserted into the top of the side panels, positioned at an angle of 45° to warranty a sufficient and uniform illumination.

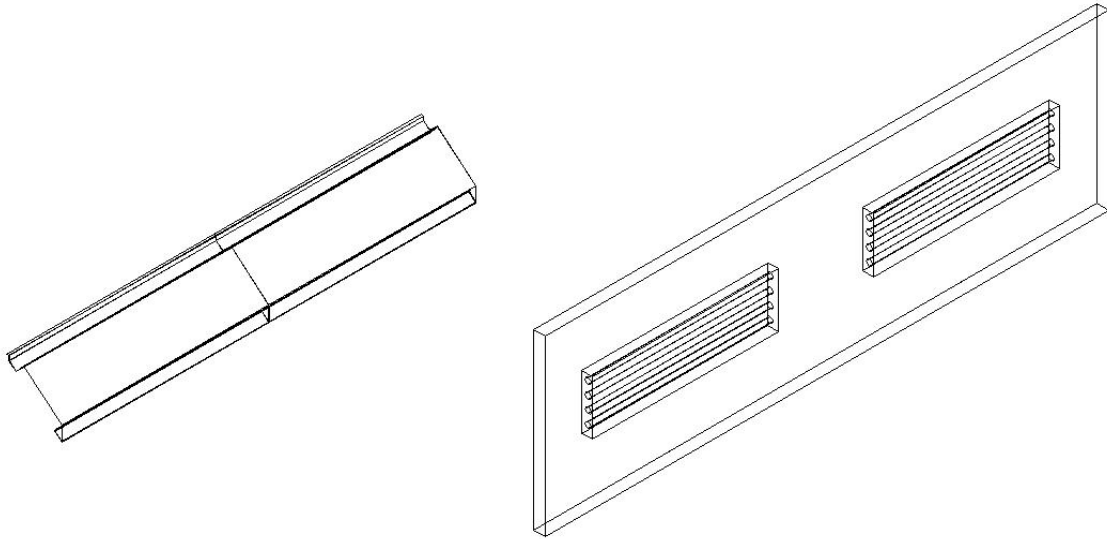

Fig. 1.4

- The overhead lights are steel plates coated with paint ,in which four neon holders are positioned, each of which fits four neons of 36 W, the neons are isolated from the spray painting environment by panes of glass as the same type of it used for the doors.
- In order to reach the better illustration effect,we usually install the side light in the side wall, the neons are isolated from the spray painting environment by panes

4) Ceiling

The ceiling acts as both a cover for the spray painting environment and supporting for the air filters at the entrance, it is composed of: (shown in Fig.1.5)

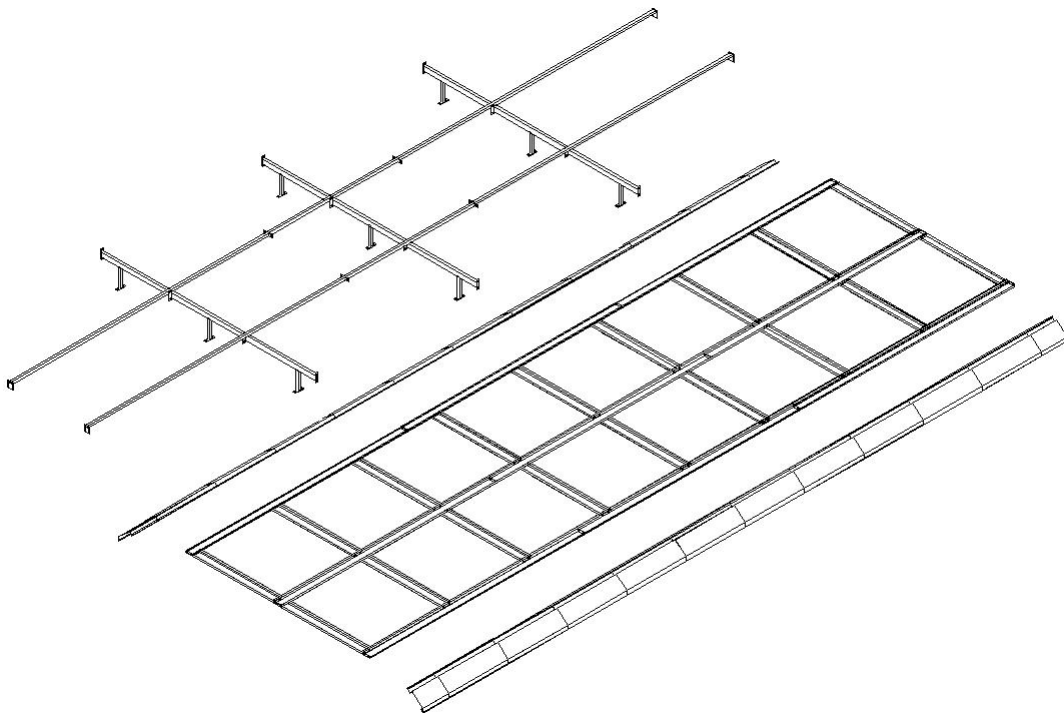

Fig. 1.5

- Top lights, including the neons of the illumination of the booth, they are the parts of the air cabin.
- The filter frame, which are hanged with the top sealing panel.
- Roofs, they are plates of zined plate that are necessary for the cover of the booth.
- The iron supporting beams, intercross by horizontal beams and longitudinal beams, which are used for supporting the ceiling.
- Top sealing panel is installed on the supporting beams. And the top sealing panel are necessary to cover the ceiling and hold up the filter frame

5) basement

The basement serves as a plenum chamber which lead the exiting air from the booth. It is composed of (shown in Fig.1.6)

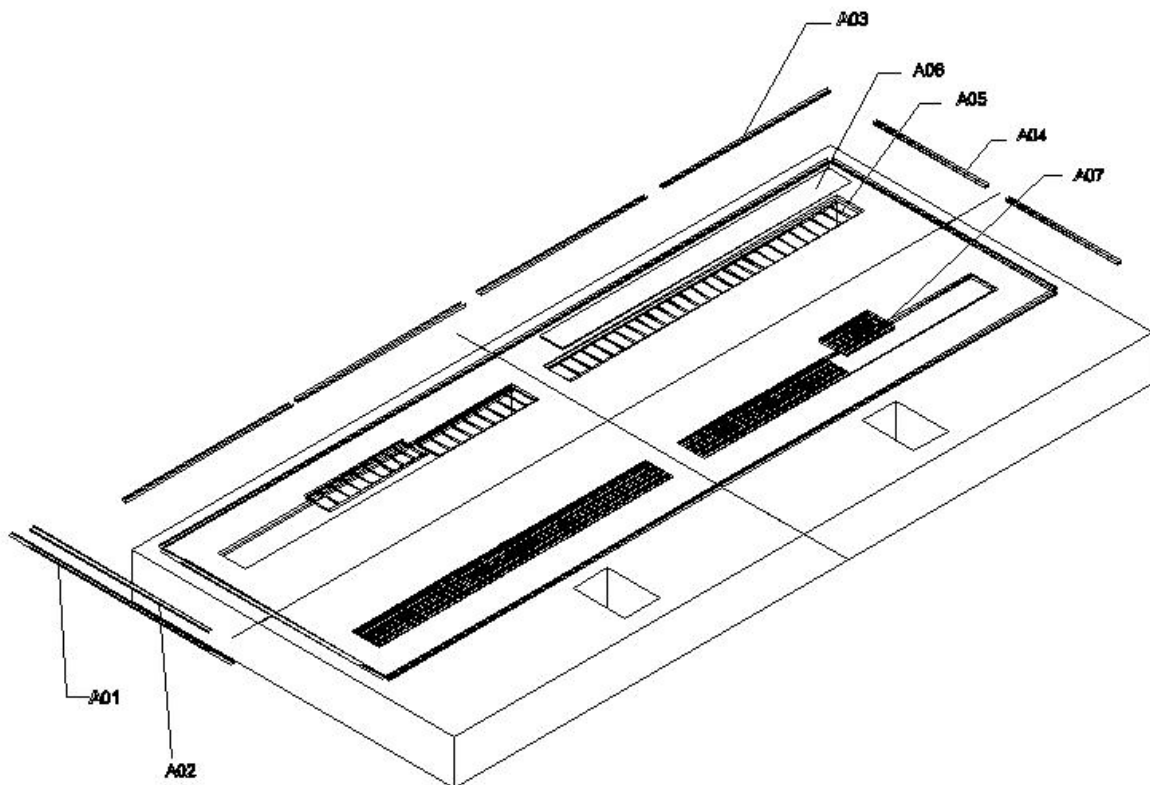

Fig. 1.6

- Basement, the user dig the two row of hole and through to the bottom of generator according the basement drawing which offer by manufacture.
- Floor filter supported frame under the filter for supporting the filter.
- Floor filter, is necessary for painting filtration.
- Grids, that are inserted in the basement necessary for the flooring.

1.1.2 Generator Part

The generator unit is necessary to start the forced ventilation needed for an optimal aerification and a homogeneous distribution of the paint to produce the quantity of heat necessary for the drying process. All the components of the generator unit are to be found in a closed booth . And the spray painting booth

consisting of (shown in Fig.1.7)

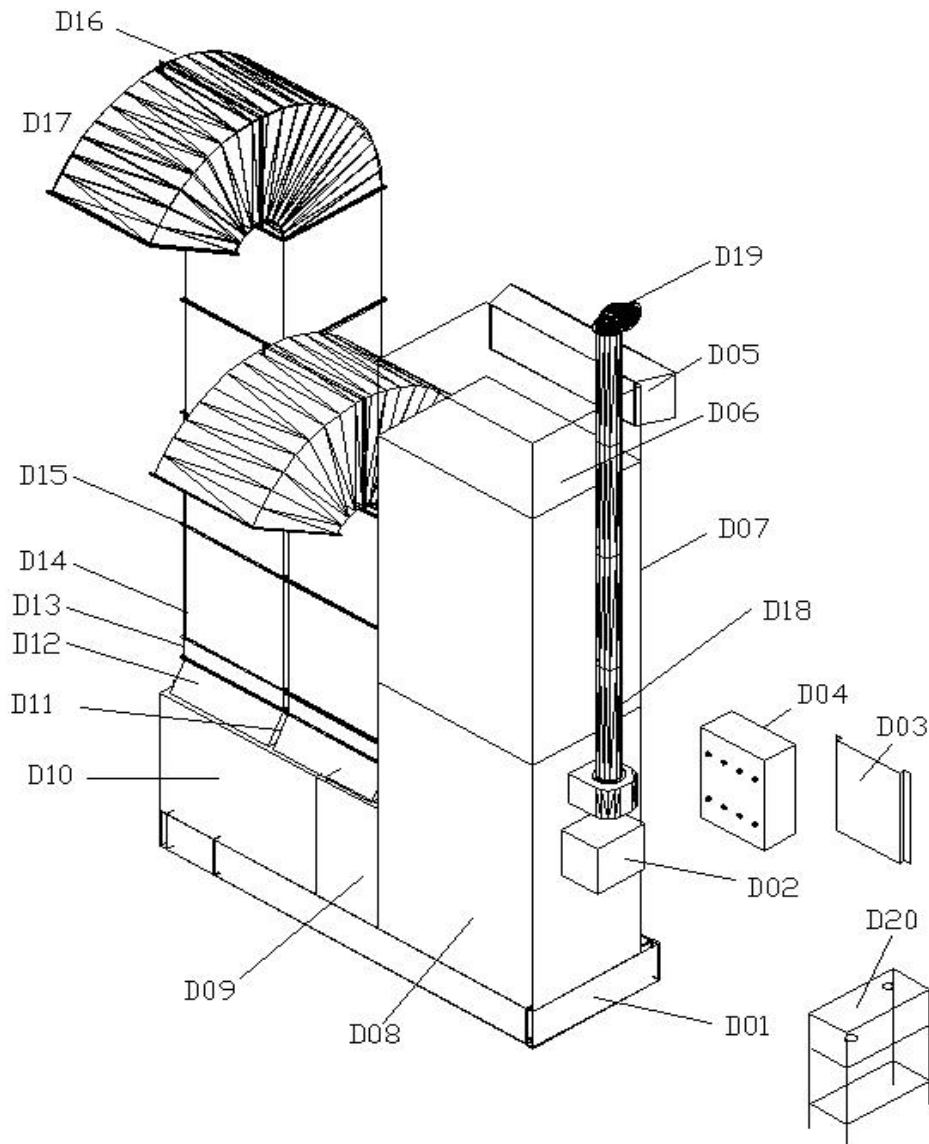

Fig. 1.7

- Connector, for the connection between the generator unit booth and the spray painting environment. Anti-vibration coupling in canvas is option so that the mechanical vibrations produced by the motor are not transmitted to their booth.
- Combustion room , equipped with a stainless steel heat changer and anti-exploding porthole as optional.
- Burner: Riello Diesel oil burner for standard. And the gas burner for option.
- Centrifugal fan , action by an electric motor.
- Enter filter frame, for pre-filtering incoming air.
- Damper system, which is pneumatic drive. it is necessary to a partially recycle the air to be introduced in the painting and drying process phase.
- Air duct: take the exhaust out of the working area.
- Chimney: take the exhaust heat out of the working area, is connect with flange.
- Active carbon environmental system

1. 1.3 Control panel

The whole system have three pieces of control box,one is main box (shown if Fig.1.8)and another two is assistant box(Shown in Fig.1.9)The control panel is composed of the following switches and indicators

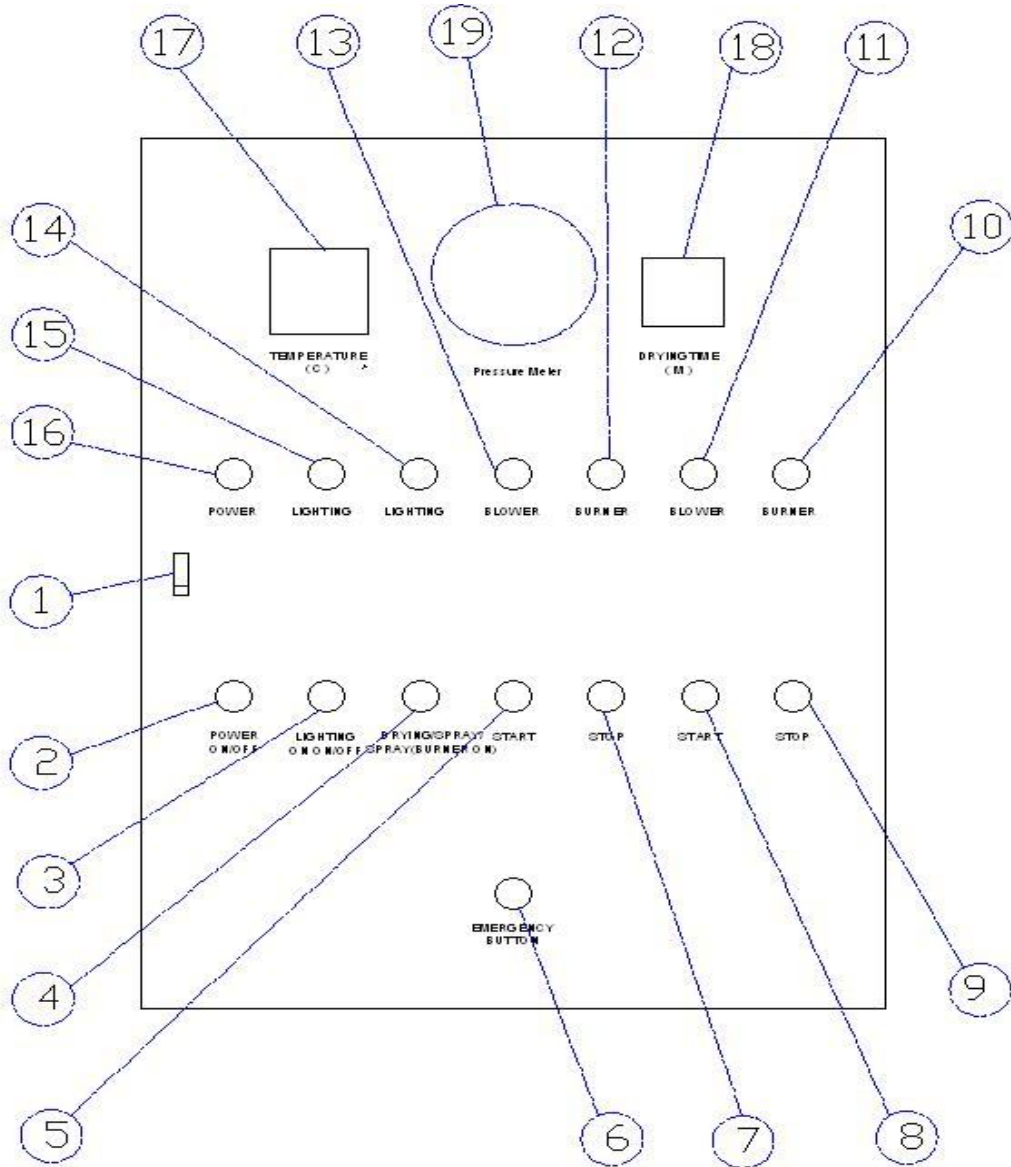

Fig. 1.8

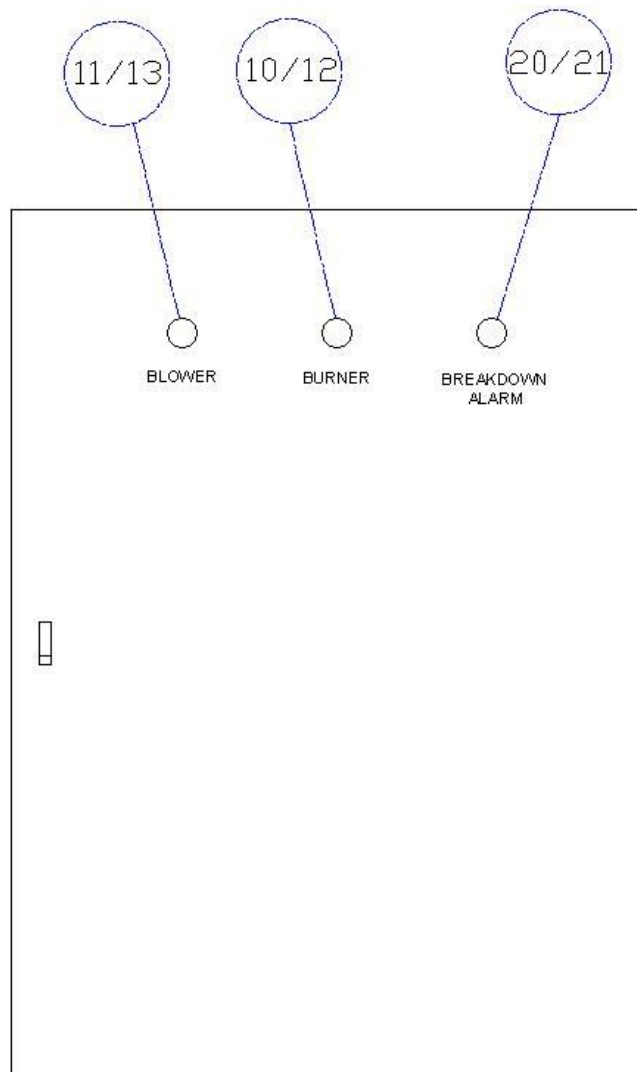

Fig. 1.9

- Switch to block main doors(1)
- Drying process Timer(18), it is necessary in order to regulate the drying process.
- Temperature meter(17), it is necessary to regulate the temperature of the air both for the spray painting and drying process.
- Burner indicator(10/12), it indicates the burner is operation or not.
- Burner Break down alarm(19/20), it alarms if there are something wrong about the burner.
- Light switch(13),turn on or turn off the up and side light.
- Emergence stop button (6),which can cut off the power when the emergence happen.
- Selector switch of Painting and drying process(4), allows the passage from the spray painting phase to the drying process and rise temperature painting.
- Stop button(7/9), press it when you want to stop the fans.
- Start button(5/8), press it when you want to start the fans.
- Power ON/OFF(2), turn the key when you want to start or close the power.
- Power Indicator(16), it indicates the power is on or off.
- Motor operation Indicator(11)&(13), it indicates the motor is on or off.

1. 1.4 Some Optional parts

1.1.4.1 Safety Thermosta

The safety thermostat(shown in Fig.1.10), placed in the generator group near to the heat exchanger, switches off the electric system if the air flow reaches a temperature superior to 90°C



Fig. 1.10

1.1.4.2 Anti-vibration Joint

The anti-vibration joint(shown in Fig.1.11), placed between the generator groups, and exhaust air unit with active charcoals and the spray booth, is necessary to isolate the vibrations produced by the motor and the fan. The joint is formed by two edges of zined plate connected by a belt of PVC that by contorting does not transmit the vibrations to the work environment.



Fig. 1.11

1.1.4.3 Active carbon system



Fig. 1.12

The exhausting air unit with active charcoals, which the air from the spray painting environment and to decrease the percentage of polluting agents. It is composed of:

- Metal frame, there rock in the panel which can keep the temperature
- Filtration group, composed of seven layer of active charcoal which remove the solvent fumes (purification plant).

1.2 The principle of the spray booth

The spray booth is in a dustproof closed environment in which a flow of air of the capacity and temperature necessary to make the booth function circulates. It works in two ways, one to carry out the spray painting phase/flash period and one for the drying phase. The pressure inside the booth is kept slightly greater than the atmospheric pressure (60mm H₂O), so that it can prevent the dust get into the booth during the operation.

1.2.1 Spray Painting Phase

During the painting phase, both the intake fan and exhaust fan are open, and the damper shutter place the position shown in Fig. 2.15. The air capacity, aspirated from the outside by means of the generator fan is prefiltered passing through the pocket filters, heated to the desired temperature (about 20°C), and introduced into the plenum. Here an even distribution is obtained and there is a second filtration through the ceiling filter. After the filtration, the air crosses the booth from the top to the bottom part picking up the paint pigments and the solvents left by the spray painting, it is then aspirated by the exhaust air unit passing through the filters placed in the purification plant. (shown in Fig. 1.13)

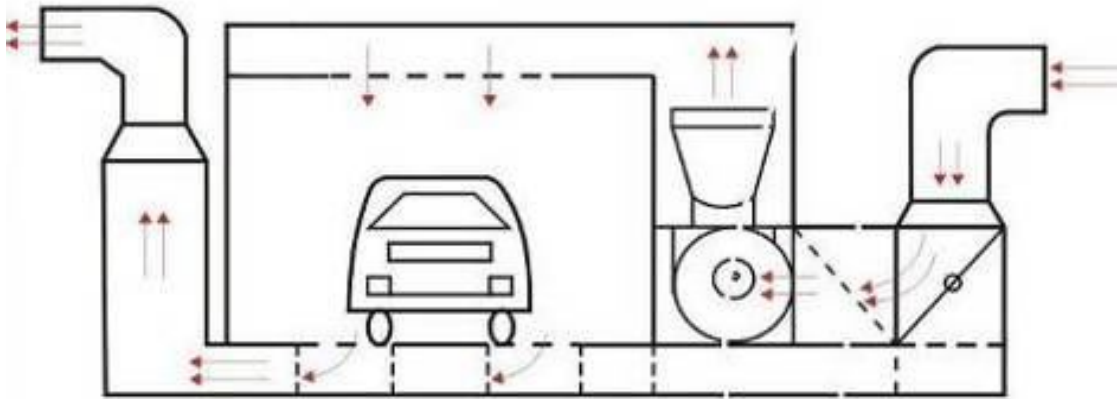

Fig. 1.13

1.2.2 Drying Phase

During the drying phase, exhaust fan will be turned off, the intake fan still operate, the damper change to the position shown in Fig. 1.14. At the same time the burner start to operate, and supply the heating for the booth through the heat-exchanger, and the enter into the internal cycle system. The ventilation style is similar to the painting phase, but the air through the basement will be taken into the intake fan again and form the internal cycle system. The temperature of the air has to be fixed according to the type of paint. Usually the set temperature should be 60°C

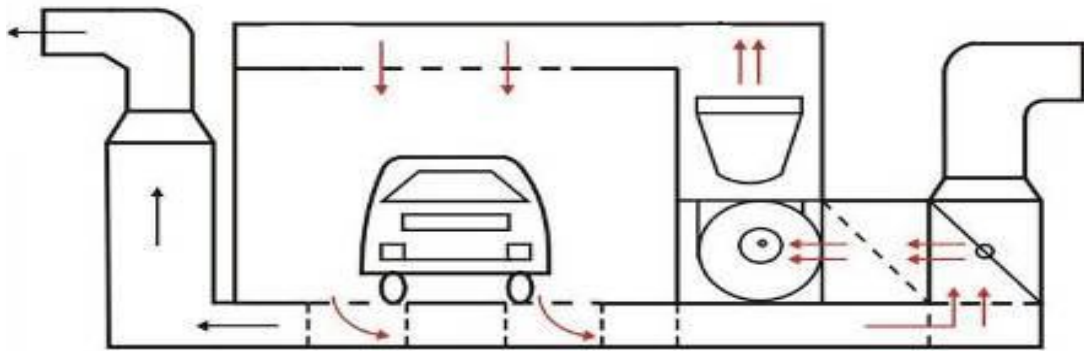

Fig. 1.14

1.3 Technical Parameter Difference

Sheet 5-5

Parameter \ Model	GL10
External Size(M)	15.2X6.7X5.0
Internal size(M)	15X5.0X4.4
Main Door size(M)	4X4 (WXH)
Thickness of steel(mm)	0.426
Filled material thickness	75mm(PE)
Fan capacity(M3/S)	72000
Air velocity (m/s)	0.3-0.5
Drying Temperature	60°C-80°C
Power (KW)	50
Intake Fan(KW)	2x11
Exhausted Fan(KW)	2x11
Switch Damper	Pneumatic style
VCD adjust damper	4 pcs manual style
Top Light Box	20×4×36W
Side Light Box	16×4×36W
Ceiling frame	16 pcs
Floor	No metal basement,dig two hole for ventination
Ramp	No
Burner	Italy RIELLO RG5S,2 sets
Motor star method	Y/△ start connect
Pressure Meter	1 pcs
Auto Suitable	Bus/truck
Remark	--

Chapter 2 The Installation of the Spray Booth

2.1 The Installation Environmental Characteristics

Before beginning the assemblage work it is necessary to make sure that the environment where the booth is to be kept conforms with the characteristics below:

1. The electric power circuit has to be measured in order to ensure the correct function based on the installed power.
2. The face of the structure has to be smooth and leveled to warranty a perfect function
3. The support plan of the structure has to be of compacting material, sufficiently resistant to bear the weight of the whole machine
4. For the correct function of the booth it is necessary that it has around it the minimum space as shown in Fig.2.1.
5. it is necessary to ensure the exit of the emission pipelines and of the air extraction furthermore it is necessary that the ends of these two pipelines are positioned in such a way that the discharged air is not aspirated.

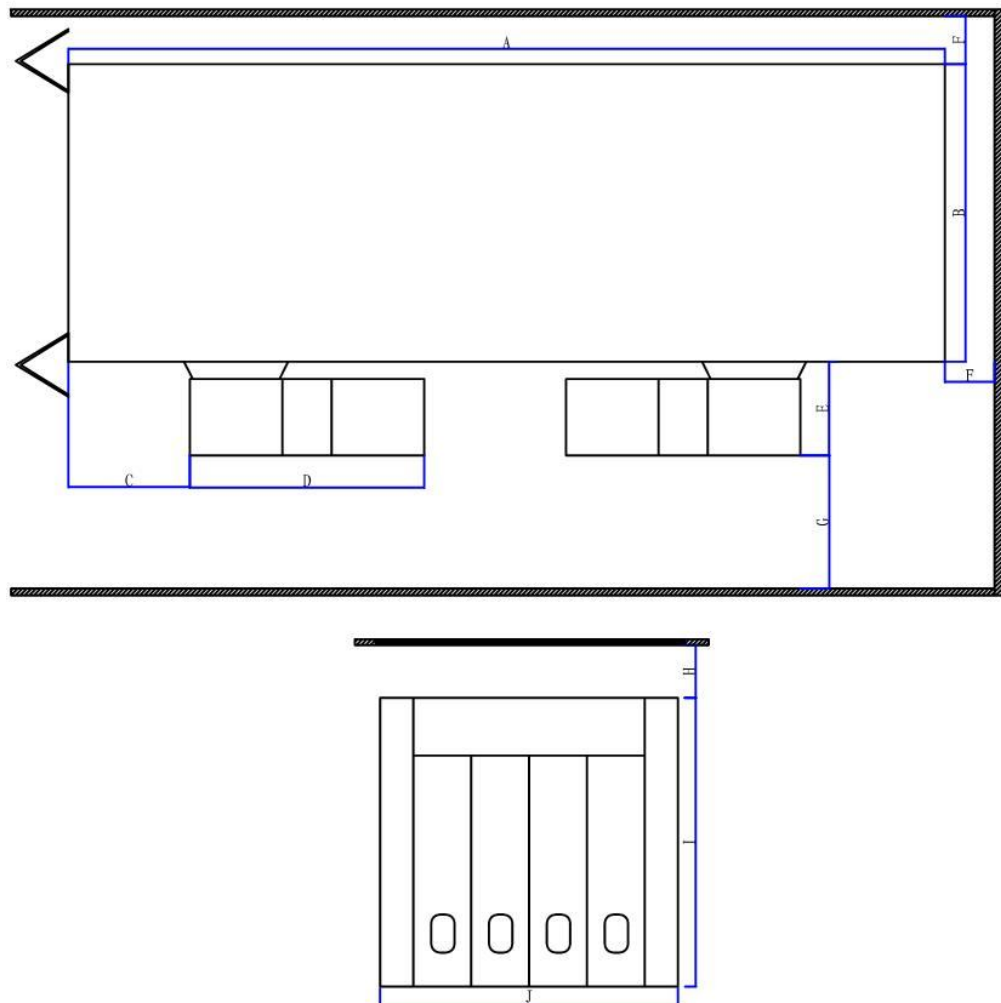

Fig. 2.1

Model (mm)	A	B	C	D	E	F	G	H	I	J
GL10	15200	5150	2100	4050	1625	500	1500	--	5000	1300

2.2 Some Necessary Tools

We will not offer the installation tools for the user,so you should prepare some necessary tools as shown Fig.2.2



Fig.2.2

2.3 Installation Methods and Steps

2.3.1 Basement installation

The basement installed step shown as the following step(shown in Fig.2.3)

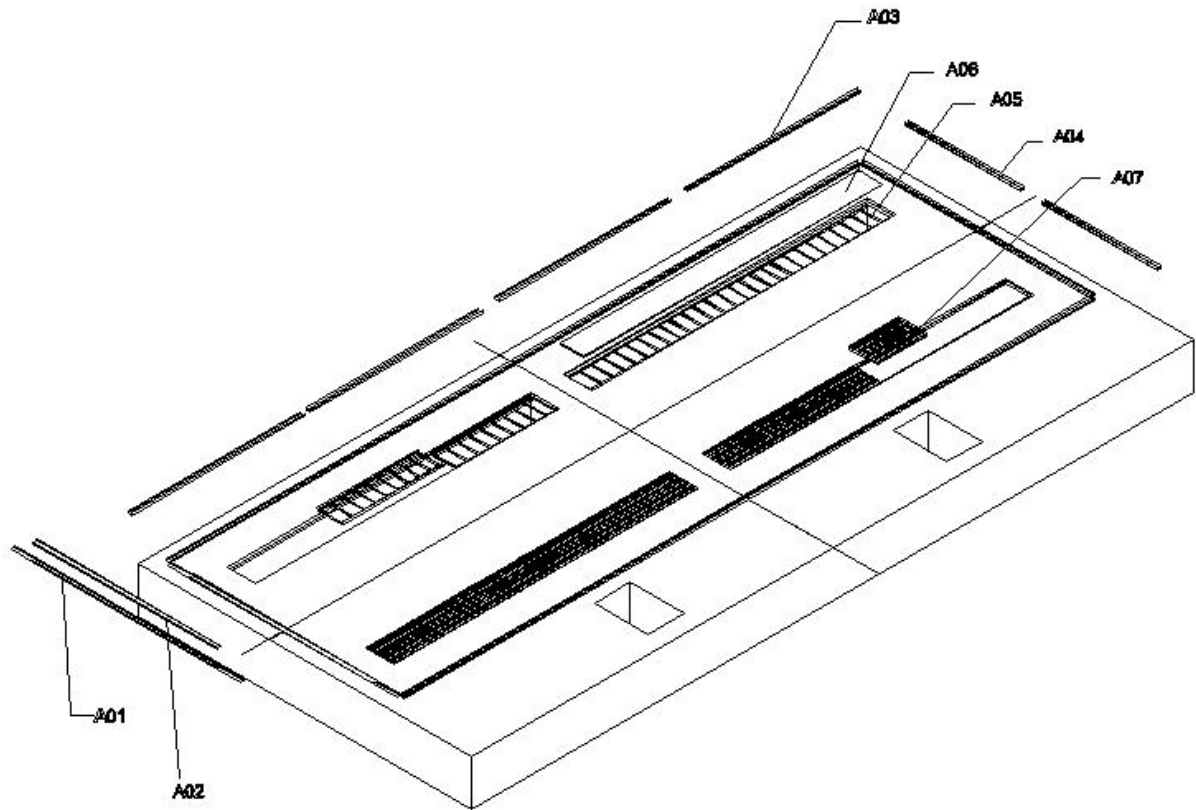

Fig. 2.3

Before installation the basement, built the basement ground according to the basement drawing which the manufacture offer. Attention to the size should be the same to the drawing.

2.3.2 Main room fram installation

1. Front door installation

Installate the front door frame(shown in Fig.2.4)

- 1) Put the left and right side panel (B01&B03)on the ground,connect the the horizontal panel(B02) with the side panel.make sure that the gap should be smallest.
- 2) Measure the diagonal of the length and width,when they are suitable for the demand of the door frame size (shown in Fig.3.4), $L1=L2$,fix the door frame with appoint connect board(B04).Pay attention to that check the sizes of the door frame after fixing.

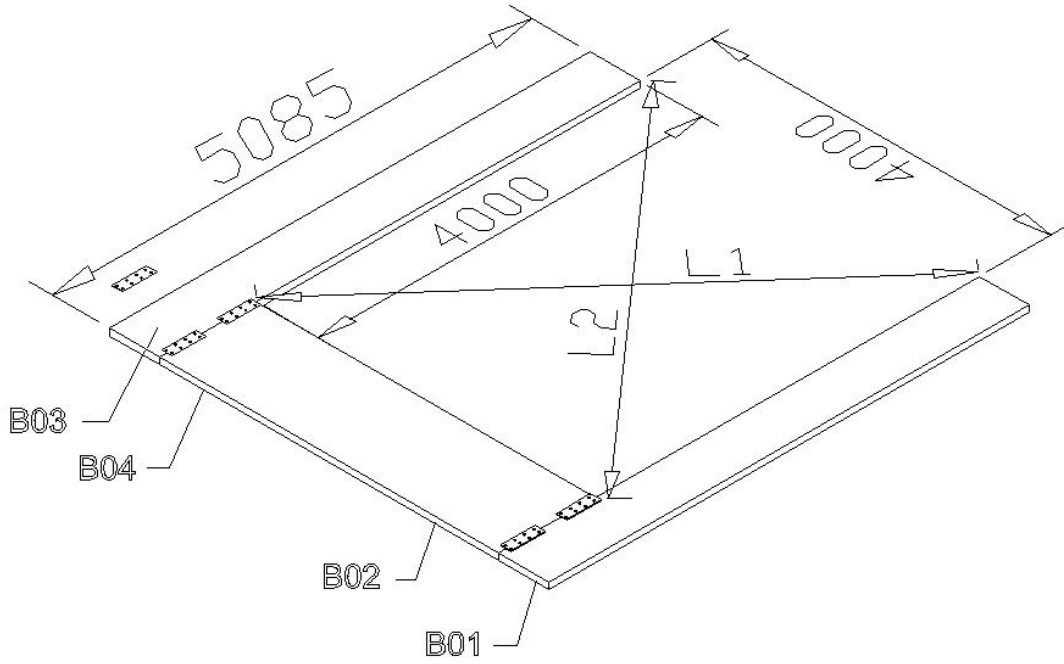

Fig. 2.4

3) Take the Front door frame on to the front panel of the basement by two workers, then one worker holds the door frame and another worker takes the safe door and one wall panel on the other side, connect them to the door frame with nails. shown in Fig.2.5. So the door frame can be stand steadily.

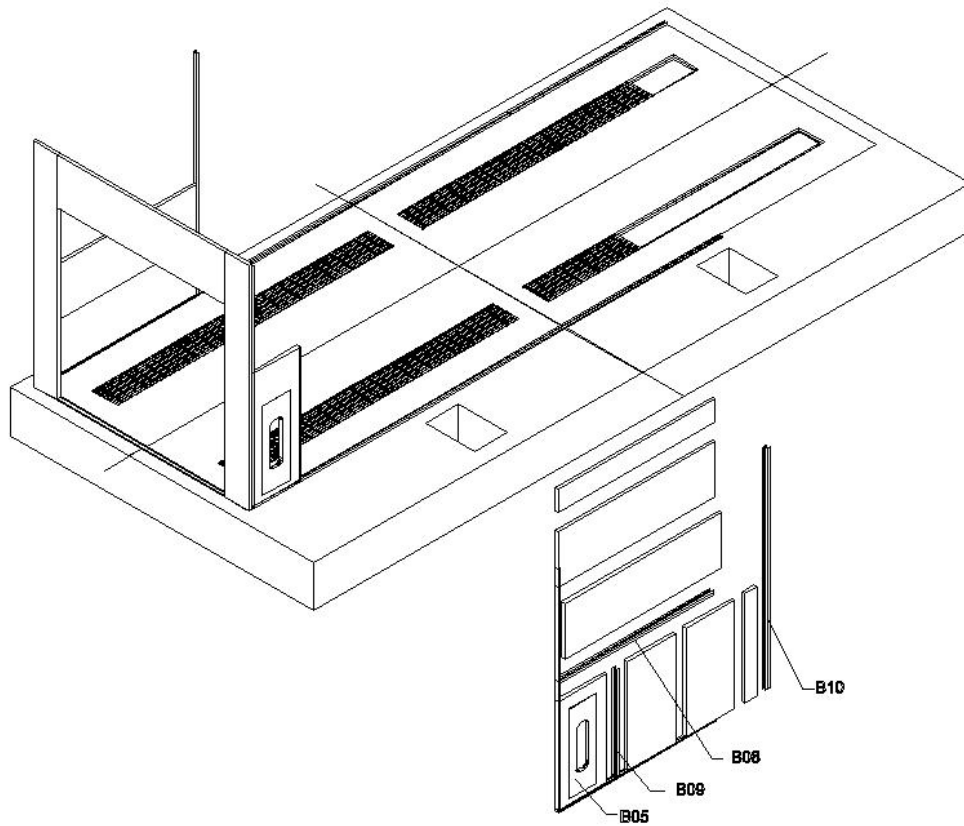

Fig. 2.5

2. Wall panel installation

1) Install the upright post, then put the wall from up to down. Connect the wall board in turn and fix the to the down U style slot with nail, make sure the gap should be smallest. Check the whole length of two sides wall board should be suit for the demand., install one cross beam to fix the two side wall (shown in Fig.2.6)

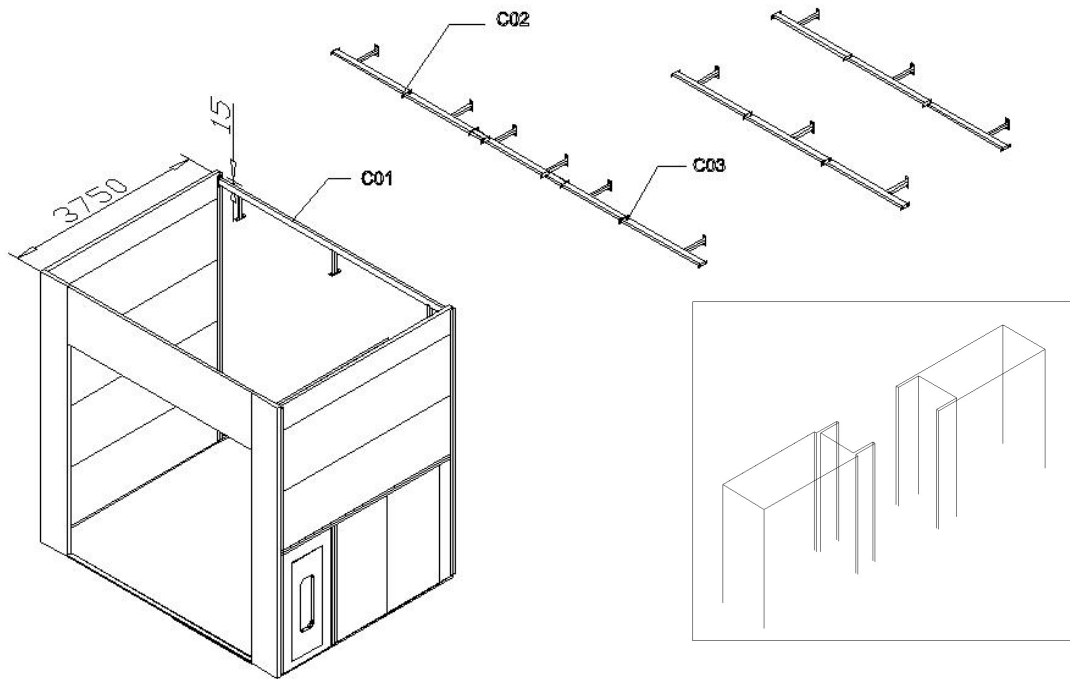

Fig. 2.6

- 2) Install other wall one by one, shown in Fig.2.7
- 3) Install the up rim of the wall panel

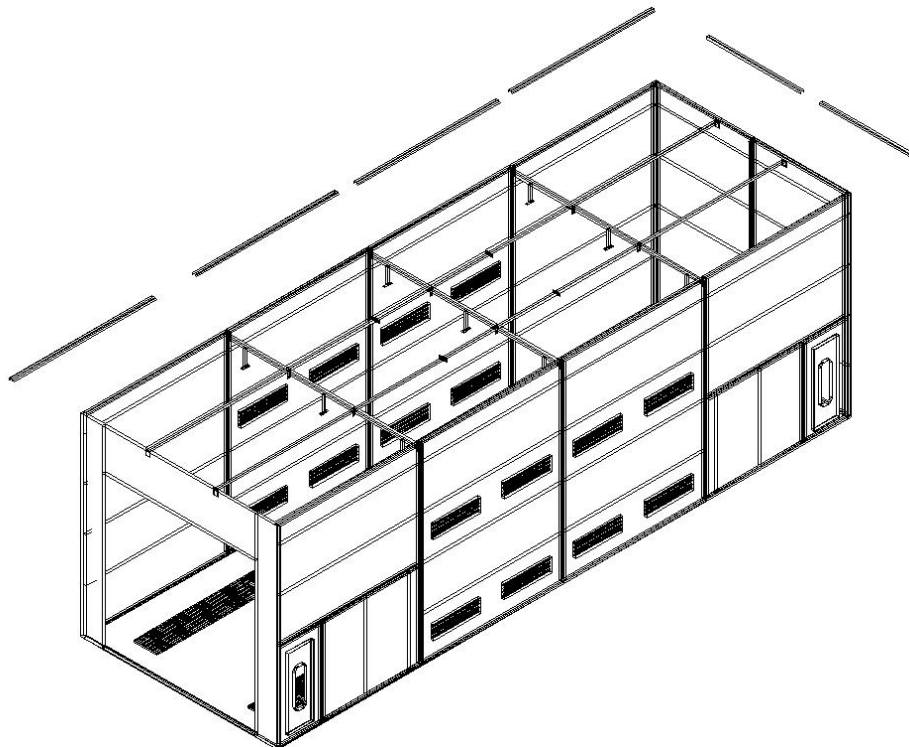

Fig. 2.7

Attention: Because the wall is too high,take care when put the wall to the up,it is better to use the lifting car or high frame to install the wall panel

3. Main door installation

Installate the door,including the lock,hinge,handle,plastic sealing bar and so on. (shown in Fig.2.8)

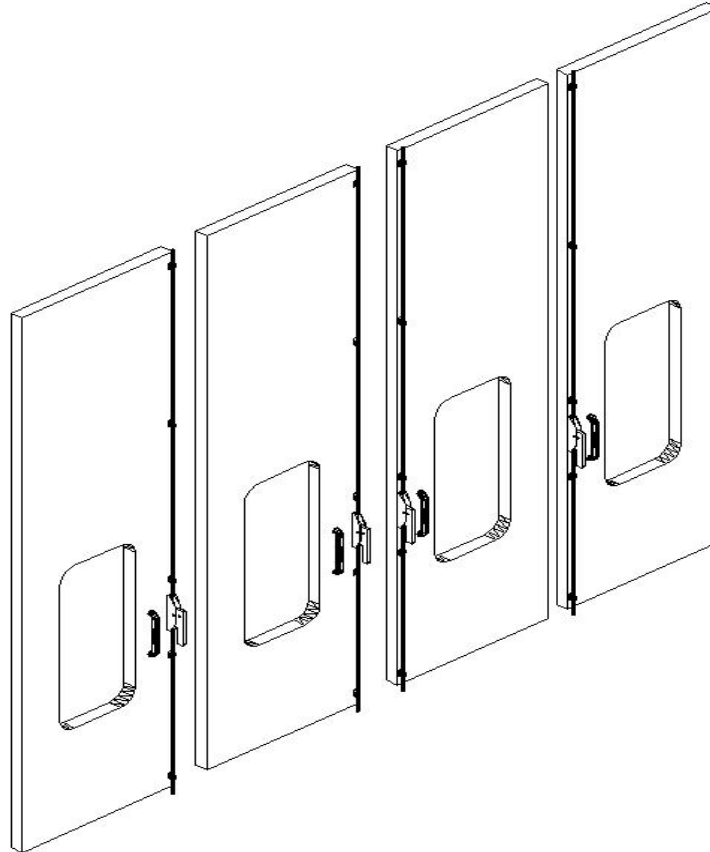

Fig. 2.8

4. Safety door installation

Safety door is necessary for protecting the worker's safety when they working inside the booth.When the pressure inside the booth is over large,the pressure lock of safety door will be open automatic.Install it shown in Fig.2.9. The pressure lock can be adjusted,not too tight and to loose is ok.

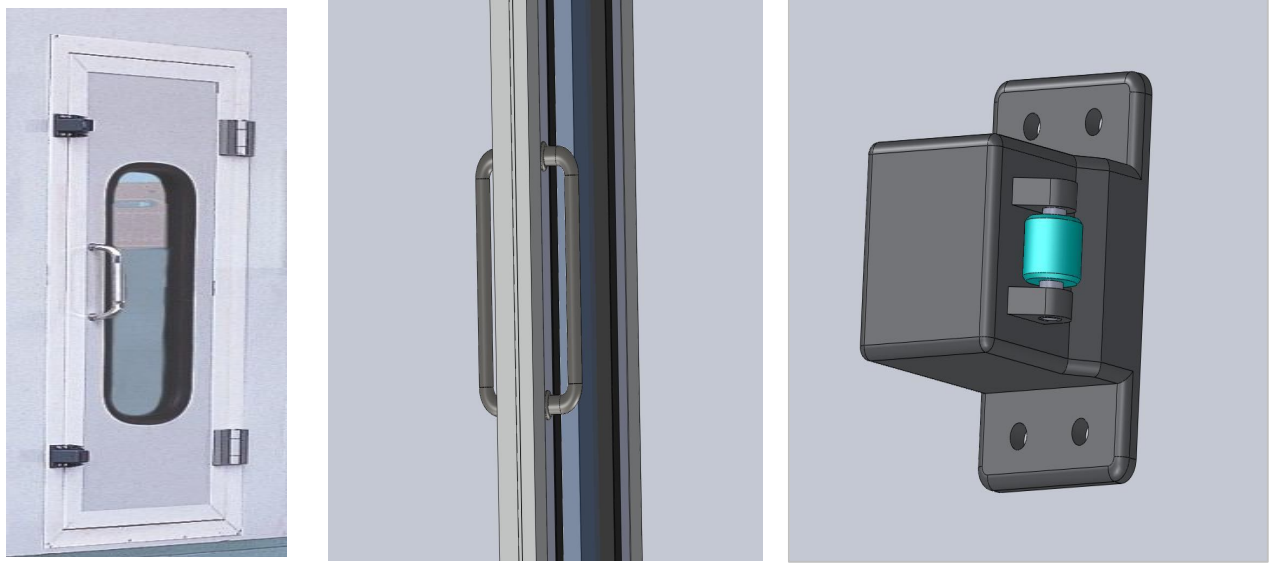

Fig. 2.9

2.3.4 Ceiling Installation

The ceiling shown in Fig.2.10

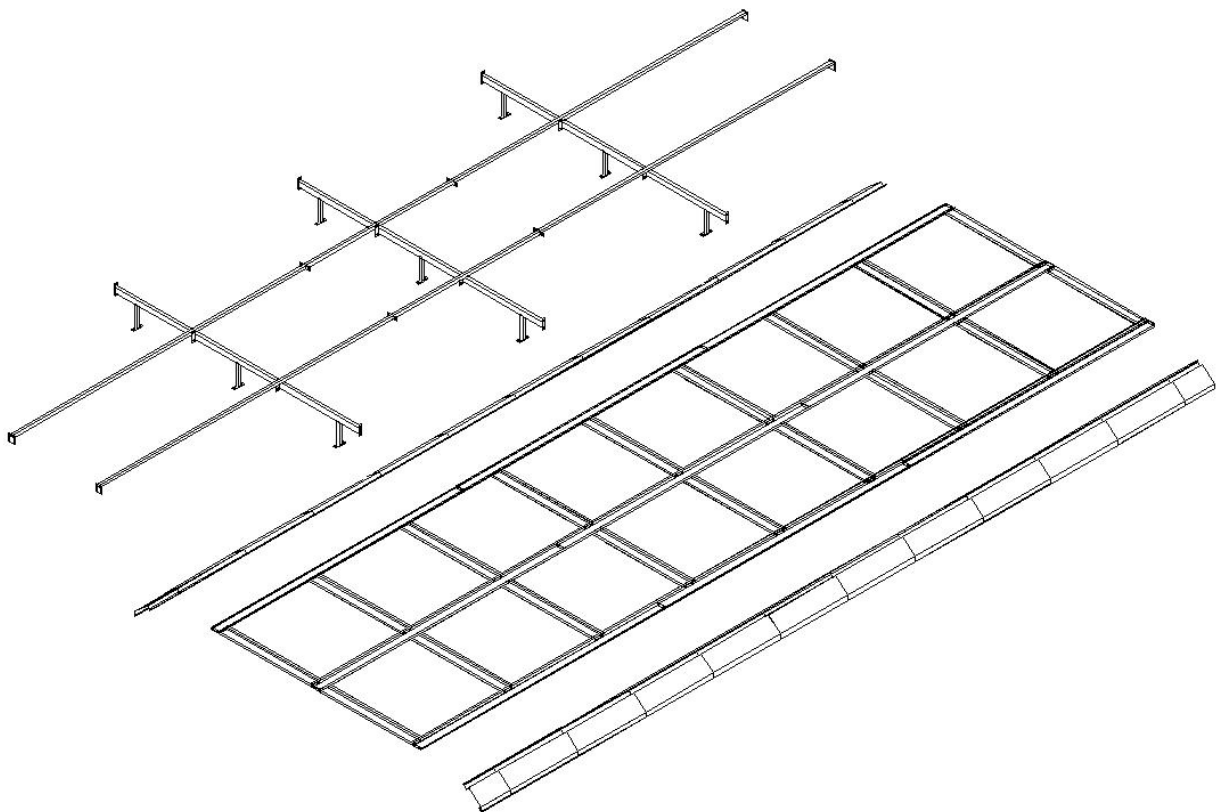

Fig. 2.10

1. Supporting beam installation (shown in Fig.3.10)
 - 1) Installate the horizontal beam to the up rim of side wall panel with the bolt.
 - 2) Installate the vertical beam to the front and back wall with nails.
 - 3) Connect the horizontal and vertical beam together with the nails.

2. Installate the top sealed board and cotton slot shown in Fig.2.11

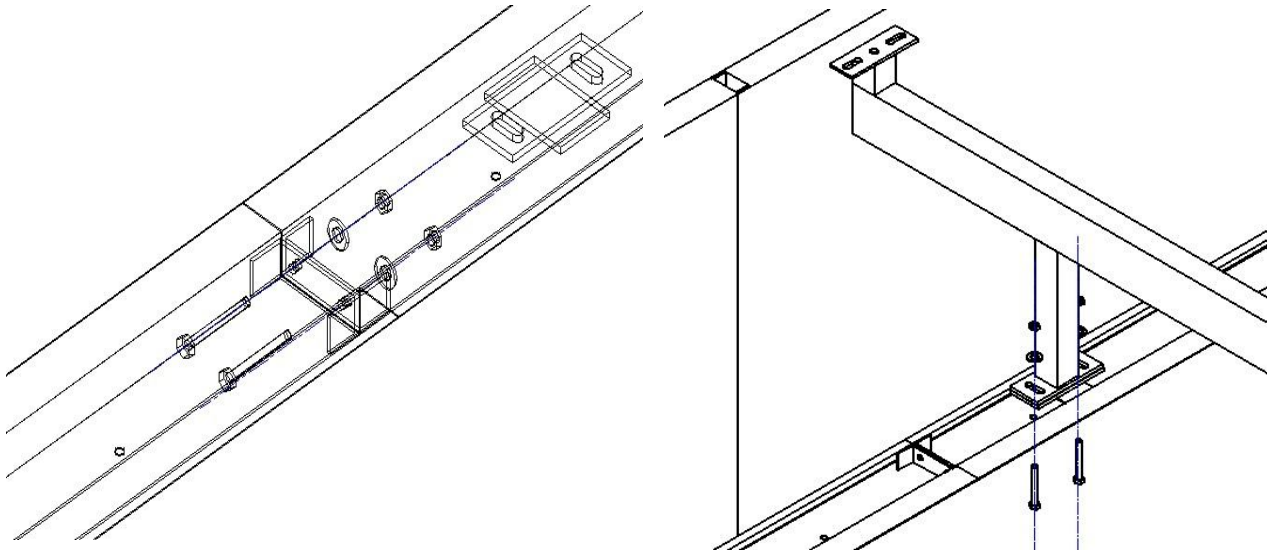

Fig. 2.11

3. Installate the light box with nails and do some sealing with the transparent pastern shown in Fig.2.12

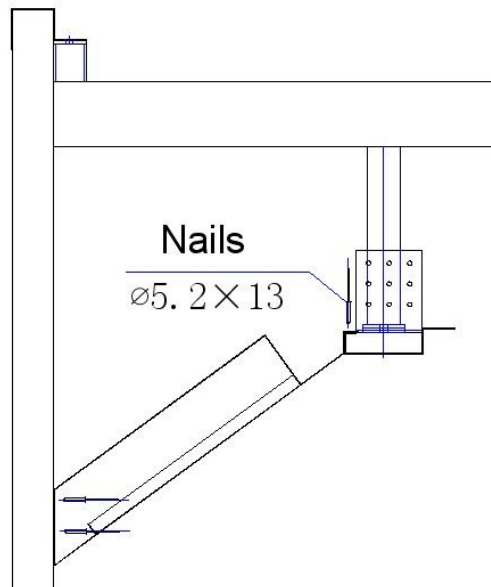

Fig. 2.12

4. Installate the roof cover ,connect one by one,then fix them on to the roof support beam with nails.And do some sealing with the transparent pastern shown in Fig.2.13

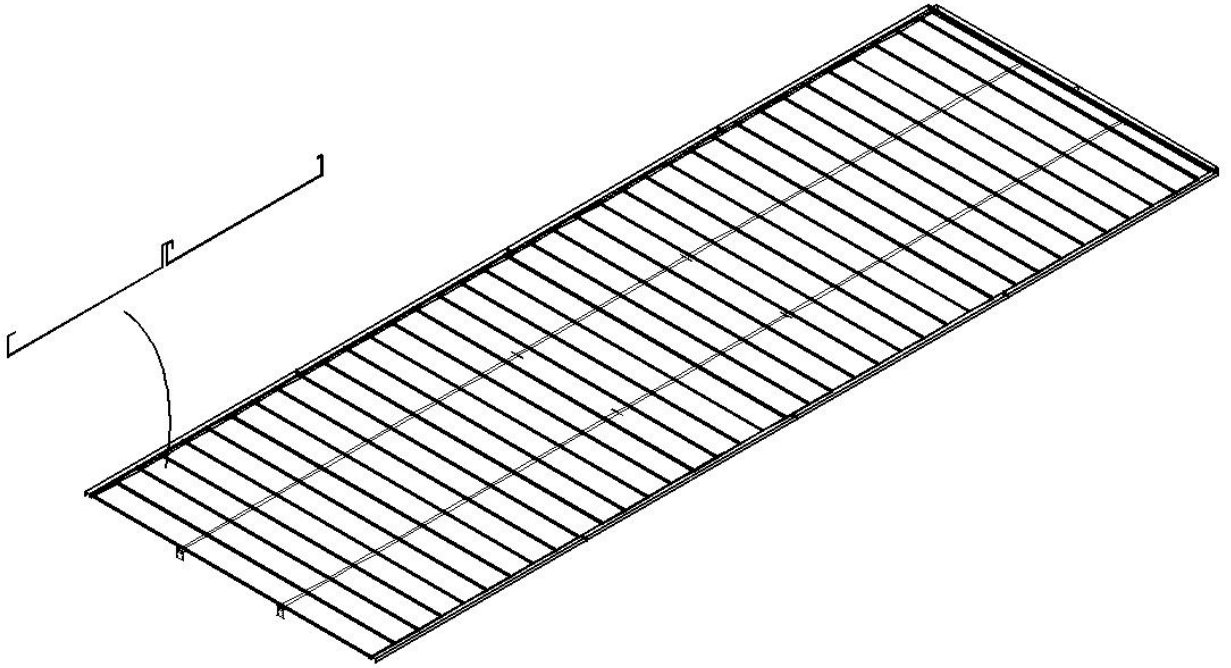

Fig. 2.13

5. Filter frame installation shown in Fig.2.14. Fix the filter on the frame with frame slot first, then installate the filter frame with the hinge.

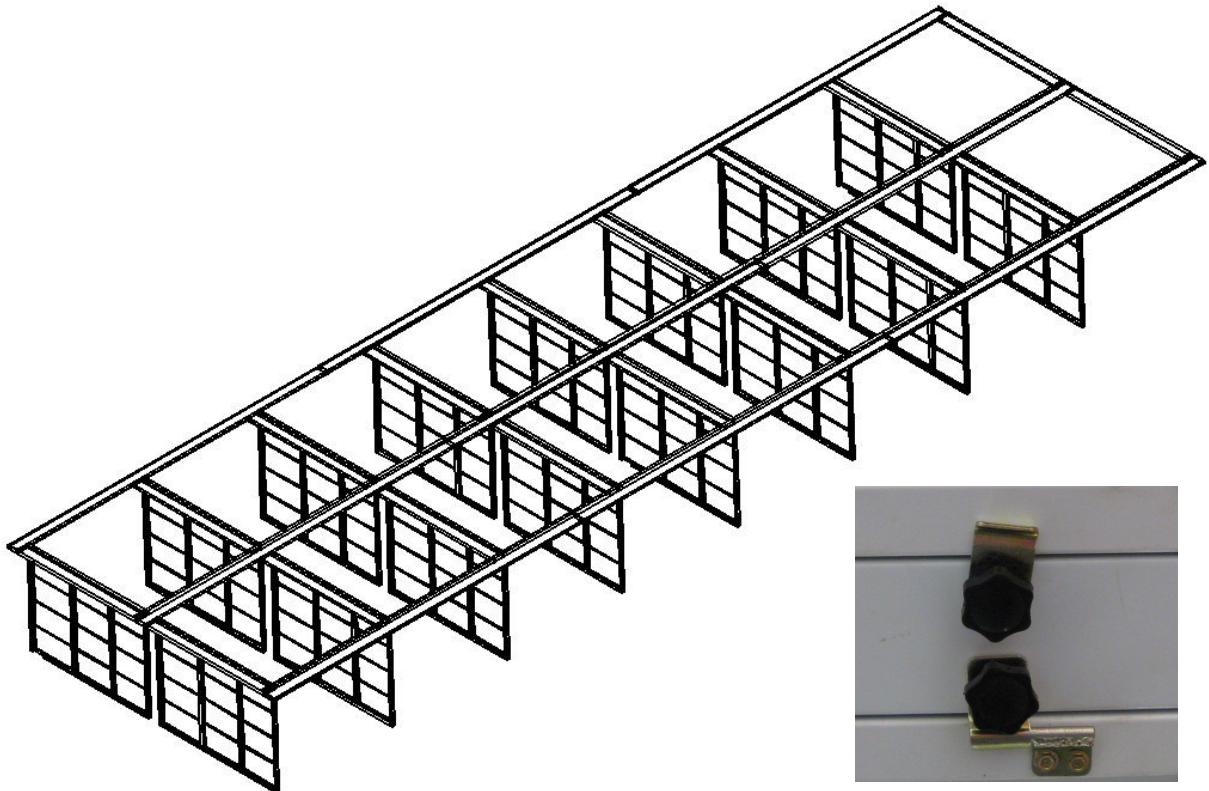

Fig. 2.14

2.3.2 Generator Installation

1. Main part installation

The generator part is the main part of the spray booth, the separate part had been installed before delivery. Connect them together shown in Fig. 2.15 is ok. The generator is heavy, so please pay attention to move them on to the basemen. Take with the Fox car would be better if you have.

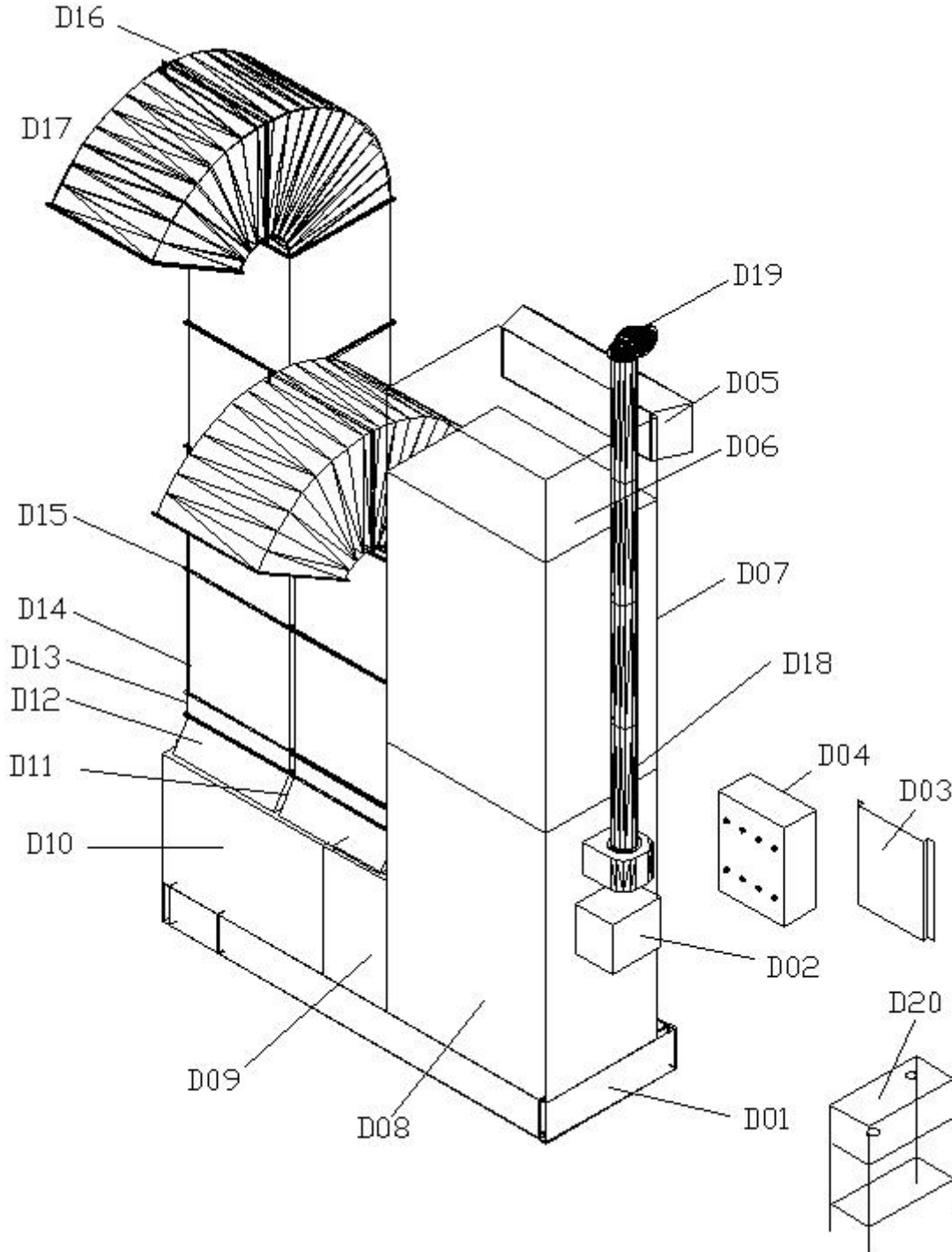

Fig. 2.15

2. VCD adjustable damper installation

The VCD adjustable damper is installed with the air enter and exhaust duct, which is used for

adjusting the air pressure inside and outside of the booth shown in Fig.2.16. Our standard model is manual control, open or close the damper by hand directly. And the electrical control for option, control by the switch on the control box.

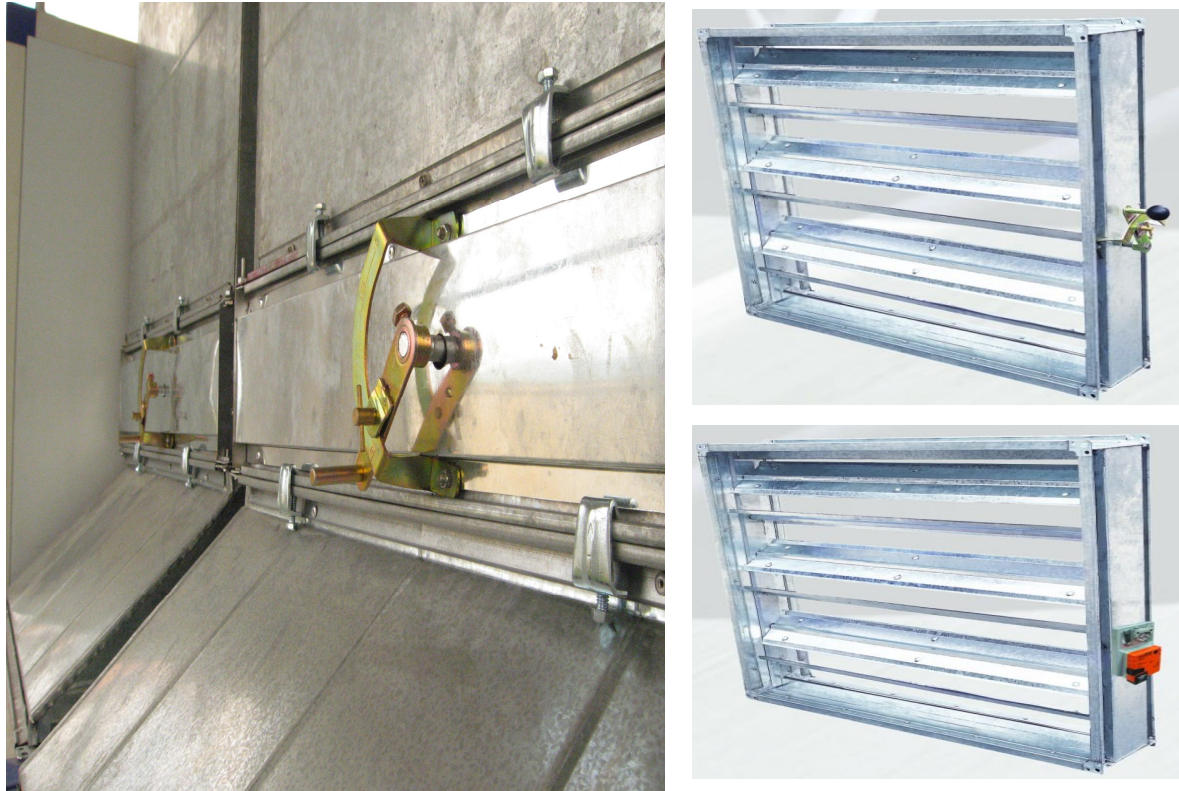

Fig. 2.16

3. Duct installation.

Considering the shipping space, the duct have not been installed, user should assemble them by yourself. The connection method shown in Fig.2.17.

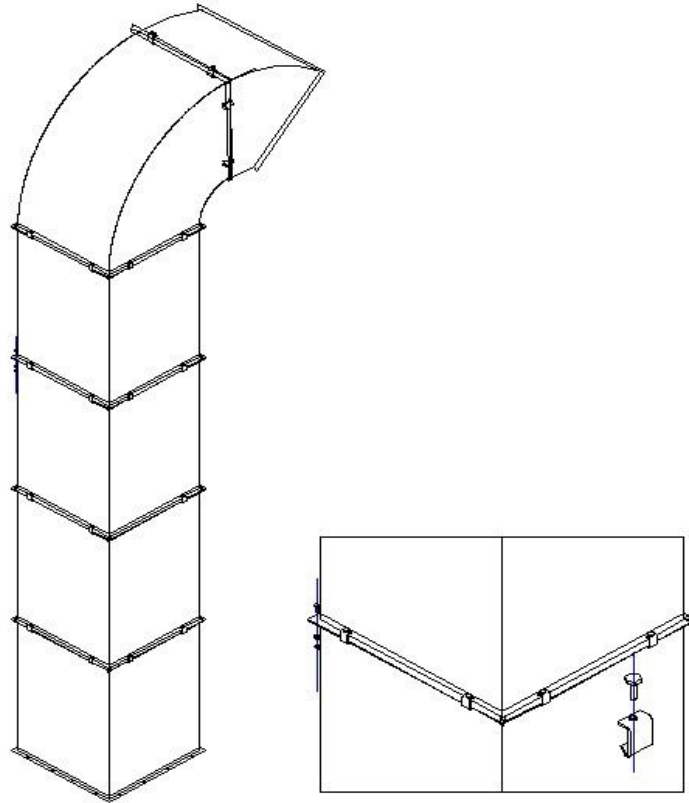

Fig.2.17

4. Chimney installation

The chimney should be connect to the fire outer of the heat-exchanger, and extent to outside. All the chimney had been assembled . So you connect it one by one. That is ok. Shown in Fig.2.18

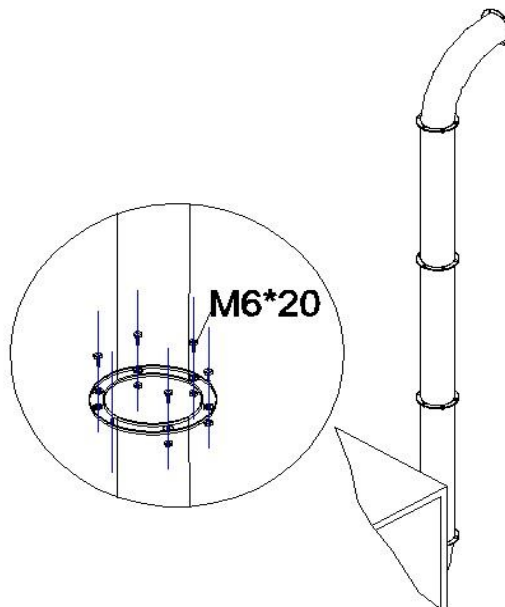

Fig. 2.18

2. 4 Control System Installation

1.Control damper installation

The damper is exchanger between painting and baking system.the installation and test shown in Fig.2.19 Connect the air pile according to the following pictures,and the air compressor should be prepared by the user.The pressure should be setted to 0.4~0.6Mpa as the pressure meter.Take the screw up and turn to adjust.



Fig.2.19



ATTENTION: There is a vane inside the damper shown in Fig.2.20.When the vane in the position A,that is the painting system,and when the vane in the position B,that is the baking system.You can test it when you operate it.If you find the wrong position,change the air pipe Port C and Port D shown in Fig.2.21. That is ok.



Fig. 2.20

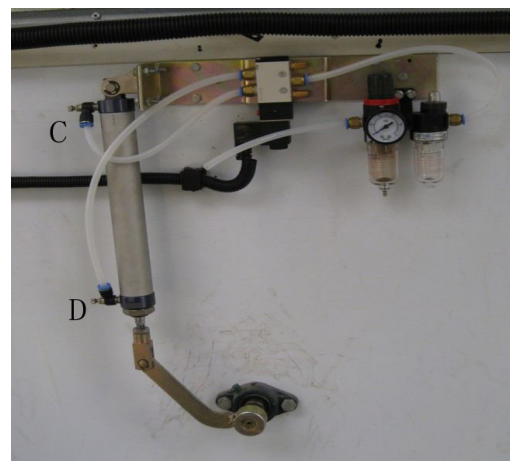

Fig.2.21

2. Burner installation

1)Install the burner to the connection mounth of the heat-exchanger,then fix it with bolts shown in Fig.2.22



Fig. 2.22

2) Connect the burner and oil tank with the oil pipe, and don't forget to connect the oil cup shown in Fig. 2.23.



Fig. 2.23

3. Temperature testing system installation

Install the temperature explorer at the middle of the ceiling inside the booth, and the wire connect to G port of the temperature meter directly through the ceiling air cabin shown in Fig. 2.24

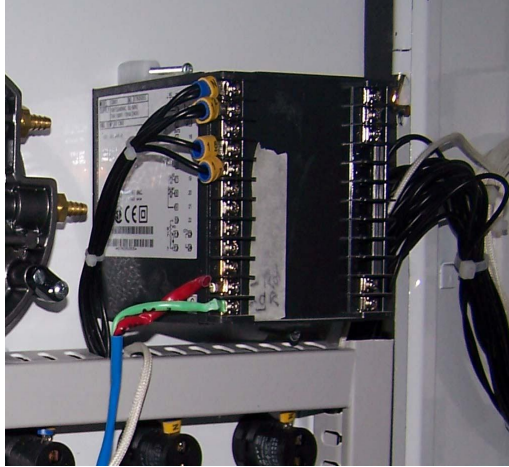

Fig. 2.24

4. Compressure meter testing system installtion

No loop for the pressure meter,just use one transparen air pipe insert one port of the meter,and another port of the meter should be plug up.The other side of the air pipe should be put into the painting room throught the ceiling air room. shown in Fig.2.25

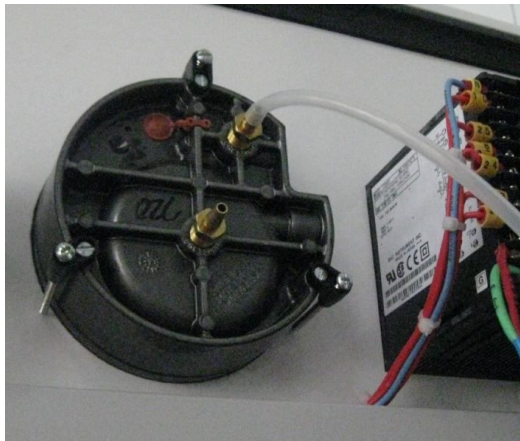

Fig. 2.25

5. The control box installation and wire connecting

1)Install the control box into to wall panel near the generator shown in Fig.2.26,and install the installation panel onto the wall with nail,then install the control box on to the panel.

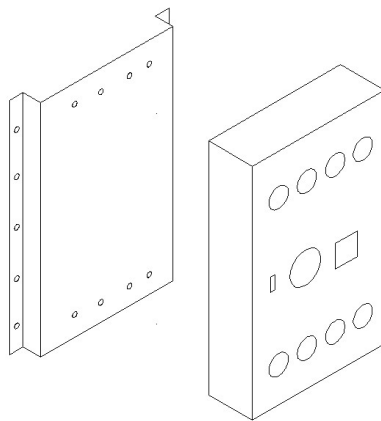

Fig. 2.26

2) Wire connection

The main component have been connected before delivery,the connection to the control box. you should do as follow in Fig.2.27:

Connect the power supply into the control box and conect the control box to the burner,motor,light and control damper with electric wires according to the electrical chart we offer.

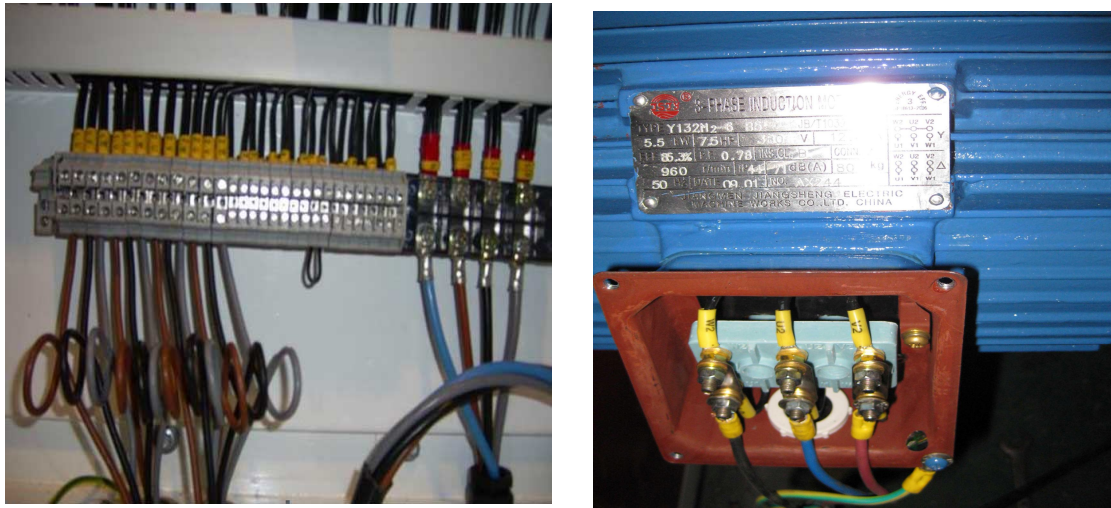

Fig. 2.27



Attention: You must connect the motor wire according to the electrical chart offered.And you must be attention to the start method of the motor,Generally our spray booth have two start methods: motor direct start connection and Y/ Δ start connection. When you choose the direct start of motor , The Up and Down ports of the motor should be connected with the metal pad, and then connect three ports (Up or Down) to the control box shown in fig.2.28. When choose Y/ Δ start connection, you must take the metal pad out, and connect to the six connection ports in the motor.

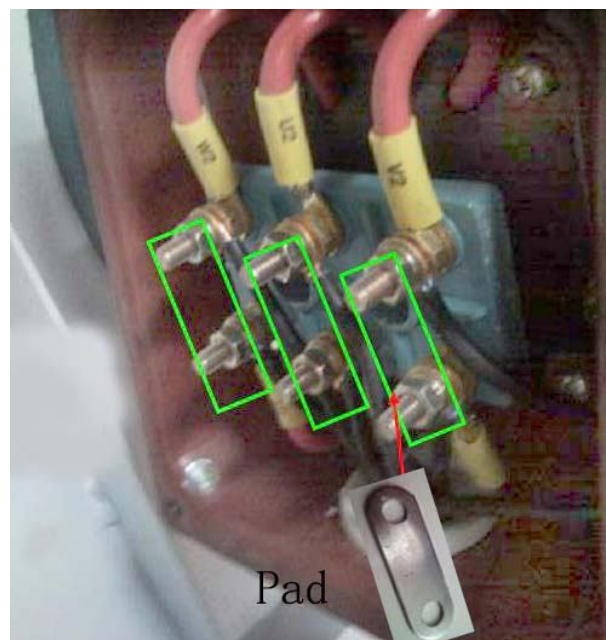

Fig. 2.28

Chapter 3 Test and Operation

3.1 Preparation Before

3.1.1 Preparation before testing and operation

- Prepare three phase electric power supply which is suitable for the motor connection.
- Prepare the air compressor for the control damper.
- Check the control system connection of the damper, the testing method as the chapter 3 mention.
- Prepare enough diesel oil in the oil tank.

3.1.2 Attention before testing and operation



- Check the connection of the electric chart according to the chart we offer. Make sure that you must ask someone who has the qualification of the electrical work.
- Check the connection of the diesel oil pile and the connector, the leakiness phenomenon is forbidden.
- Keep to all the signaling of danger and safety posted on the booth.
- The qualification of the personnel, The personnel employed to work on the booth, before beginning the work, has to have studied the "SAFETY " because during the work there will not be time. This is important above all for the personnel who only work sporadically.
- During the painting process, it is forbidden for the personnel to go into the booth, with non-regulation clothing (including necklaces, bracelets, rings etc.).

3.1.3 Test the rotation of the blower

- Intake blower testing: Open the pre-filter cabin in the generator and check the rotation of the fan, make sure the air can be taken in when the fan turn on.
- Exhaust blower testing: Take out the cover panel of the exhaust cabin, check the rotation of the fan, make sure the air can be taken out when the fan turn on.

3.1.4 Test the damper system

The main function of the damper is the transition between the painting system and baking system. The test method shown in Chapter three.

3.2 Attention Norms



- In the paragraphs below are listed all the regulations and prohibitions to be observed in order to prevent possible accidents:
- Prepare and keep paints in a place outside of the spray painting environment.
 - Clean the inside surfaces of the oven and the glass of the overhead lights from possible paint residue or solvents.
 - Use the spray paint gun correctly: spray only in the direction of the surfaces to be painted, in order to keep the operator in clean air.
 - Make sure that inside the vehicle there are not dangerous objects or substances.
 - Make sure that the emergency exit is free of objects that may hinder the opening in emergency cases.
 - Make sure that all the discharge air and smoke ducts are protected by the appropriate grates and that the air passage is not obstructed.



Inside the spray painting environment, it is **FORBIDDEN** as follows

- To introduce the vehicle to be painted without first removing the petrol tank and the battery.
- To smoke
- To use equipment that can produce sparks or flames and any kind of electric apparatus.
- To use incandescent objects.
- To paint when the temperature of the spray painting environment is more than of 25°C.
- To enter during the drying process phase.
- To use more than 150 g of paint for 1000 Nm³/h of air (corresponding to a max of 2.7 Kg/h of paint)
- To keep objects or dangerous substances such as aerosol bombs, containers and solvents,
- To wear overalls or other garments dirty with paint residue or solvents.
- To have or consume food or drinks
- To climb on the roofing of the spray painting booth, the exhaust air runoff and the generator.

3.3 Operation

The spray booth has two working station:Painting station and drying station,the two station have been connected each other and have the different operation.And during low temperature environment in the winter,we should open the burner and rise the temperature about to20~25°C during the painting station.The control panel is shown if Fig.3.1,The two sets of generator can be control separately,and the generator working station can be show in relevant control box.

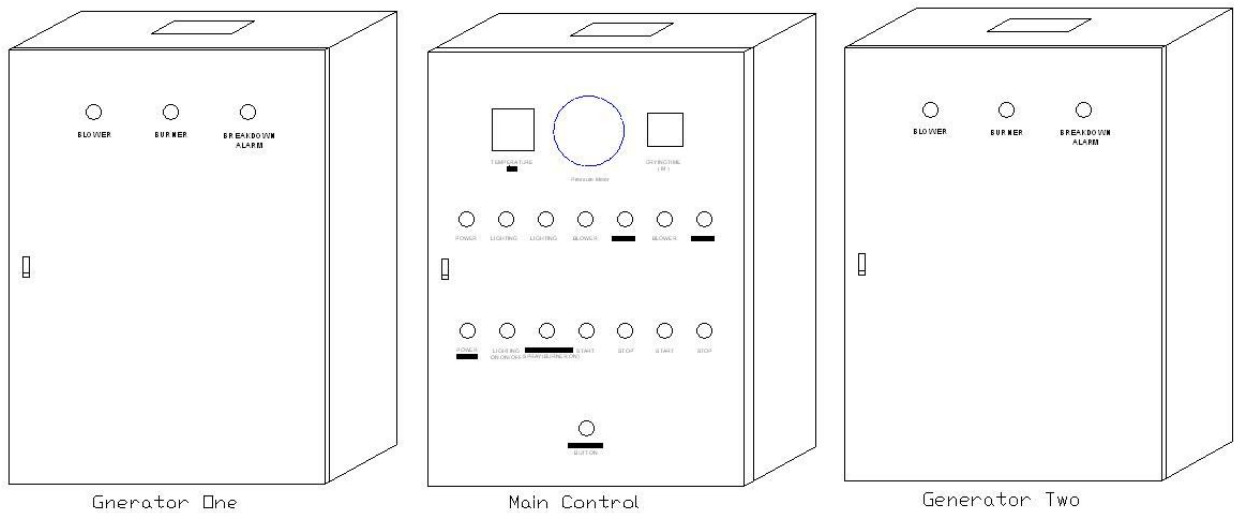

Fig. 3.1

3.3.1 Painting station

After having cleaned and prepared the vehicle, the operations functions for the painting phase as following steps.

1. Turn on the key switch to open the power supply, and press the light switch to turn on the lights
2. Drive the vehicle into the spray booth, and close the main door.

3. Check the setting value of temperature meter and dring timer, normally the value had been setted by the manufacture. And the dring temperature should be 60°C and the dring time should be about 30~45minutes.
4. Check the shuff of the damper is in the right position
5. Press the motor button to start exhaust fan , and you can see the indictor of the motor turn on. then the intake fan will start 10seconds later.
6. The worker get into the booth through the safety door and do the painting. If the temperature is low, turn the dring/painting switch to left and open the burner and rise the paiting temperature.
7. The worker get out from the booth throuth the safety door when finish the painting. Then change to baking station.

3.3.2 Drying station

The operations to follow in the drying process phase are:

1. Make sure that all the spray painting functions are ended and that the operator has gone out of the spray painting environment.
2. Check there is enough diesel oil in the oil tank and no leaking of the oil pipe.
3. Check the setting value of temperature meter and dring timer, normally the value had been setted by the manufacture. And the dring temperature should be 60°C and the dring time should be about 30~45 $^{\circ}\text{C}$.
4. Turn the dring/painting switch to right to open the burner. At the same time the damper will turn to another position and the light will turn off automatic. And the exhaust fan will turn off, but the intake fan is keeping operation.
5. The spray booth will be working automatic till the setting dring time finished.
6. When the setting dring time is finished, the burner will stop automatic first, then the motor will stop about 5 minute later.
7. The light will be turn on again after the motor stopping.

3.3.3 Machine Stop

To stop the booth before the foreseen time it is necessary to:

1. Turn the burner switch onto the OFF position (Middle position) .
2. Open the gate of the booth and let the vehicle out.
3. Switch off the lights if they are on
4. Turn the general switch onto the OFF position.
5. Wait for about 15 minutes in order to get the air condition inside the booth, then close the main doors.



ATTENTION: After drying, if there is more heating or exhaust air inside the booth, it is necessary to start again from the spray painting cycle in order to allow the reinstatement of the initial condition with an adequate ventilation.

Chapter 4 Maintenance and Repair

4.1 Ordinary Maintenance

Maintenance has to be a preventive and planned activity, seen as fundamental need to obtain safety, as a presupposition that the machines and the apparatus are subject to wear which is a potential cause of breakdowns. Therefore the safety of the booth depends also on a good preventive maintenance that allows the substitution of the objects subject to wear out before the verification of the technical faults.



Please carrying out the maintenance intervention /cleaning as the following ordinary maintenance and frequency verification instructions:

- Keep the booth clean and keep the intake and exhaust duct be open.
- Change the top filter after painting 100sets of auto or use more than one year,But in the more dust situation,that should be shorten the filter changed period according to the actual condition.
- Change the Pre-filter after painting 50sets of auto or use more than one year.
- Change the flour filter after painting 50sets of auto or use more than one year.
- Clean the filter oil cup and fire nozzle of the burner each week,keep the oil route be through.
- Add the diesel oil is forbidden when the burner is working.
- Make sure there are more than 5L oil in the oil tank,use Non diesel oil is forbidden.
- Check the filter net of the activated charcaod environmental cabinet after painting 20sets of auto or use more then 1 month.If the painting adhibit to the filter net fullled,change the filter net in time and keep the ventination be through.
- Check the heat exchanger every two months,examine whether have the bad welded phenomena,make sure saftey enough.
- Clean the dust adhered to the fans and blades semiyearly
- When you don't operate the booth for a long periods,cut off the general power,and open the door for ventination every three days,in case accumulate the moisture air inside the booth.
- Change the heat exchanger and all of the electric wire when using more than 8 years.



Maintenance in time is necessary,but the appropriate maintenance is also very important,you should abide to the following mainly maintenance method and attention problem

4.2 Ordinary Maintenance Instruction



The procedures of ordinary maintenance as a rule are done by qualified and authorized personal and however, before beginmng the maintenance, the following functions have to be done.

- Remove the motor vehicle from the spray painting environment.

- Turn the main switch to be off..
- Disconnect the control panel switching off by means of the switch place on top..
- Close the general switch with the padlock and keep the key during the phases of maintenance.



ATTENTION: All the used filters (pocket filters, ceiling filters, basement filters, synthetic filters and bunker activates) cannot be disposed of as normal urbanwaste, neither can they be burnt, but they must be given to the appropriate authority for disposal.

4.3 Some Spare Parts for Maintenance

- Ballast for the light tube.
- Fuse for control box.
- Light tube for lighting
- Filter for dust prevent

Chapter 5 Packing,shipping and Storage

5.1 Packing

The oven booth is generally delivered in various sub components palletized and in different packaging.

The handling of the packages has to be done using the correct means of capacity transport for the weight to be lifted.

In some cases the components are systematized loose in the loading bay (container, truck, etc.)

in such cases it is necessary to unload and move the various individual parts and in such a way as to warranty the maximum safety for working personnel. Some package shown as the following picture.



Fig.5.1

5.2 Shipping



During the handling operation it is forbidden for third persons to go near the lifted load.

- The points indicated with the arrows are those to be used for lifting.
- In case a crane is used verify that the capacity of the hemp bands is enough for the weight to be lifted.

If the generator unit and exhaust air unit with active charcoal are supplied already assembled they are to be moved with a dolly elevator of sufficient capacity (see figure) forking the unit as indicated.

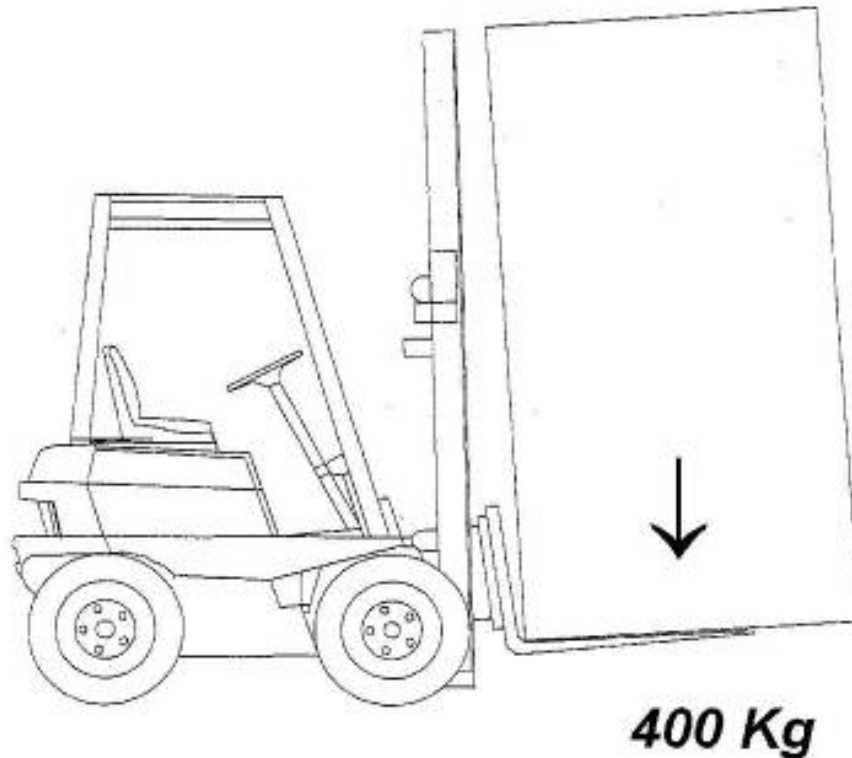

5.3 Storage

Under the case of storage of the booth before unpacking, it is necessary to put it in a place protected from bad weather, that is fresh and dry.

After having transported the booth package to the place destined for the installation, remove the wrapping and verify that:

- a. The content of the package corresponds to what was agreed upon in the order.
- b. That there are not visibly damaged parts.

In both cases, in case problems are encountered, do not proceed with the assemblage of the booth and warn the builder immediately of the damage and/or of the missing parts ascertained. on the opening the wrapping.



The residue material of the packing is disposed of in accordance with the actual normative in force with respects to waste disposal

Appendix I : Malfunction and Remedy

MALFUNCTIONING	PROBABLE CAUSE	REMEDY
The moter can not Start	<ol style="list-style-type: none"> 1. Fusing fault 2. Thermal relay in operation 3. The motor,wires circuit break 	<ol style="list-style-type: none"> 1. Change new fuse 2. Push button of thermal relay reposition 3. Change the moter and wires
The Capacity of the fan is small	<ol style="list-style-type: none"> 1.Pre-filter Jam 2.Damper have been right open or not open enough position 	<ol style="list-style-type: none"> 1.Clean or change the filter 2.Open the damper completely
Burner malfunction light turn on after the burner have started 20 seconds	<ol style="list-style-type: none"> 1. Use out of oil in the reservior 2. Oil pipe connector leakage 3. Too dirty in the filter net of the oil intake pipe 4. Electrical ege is too dirty 	<ol style="list-style-type: none"> 1. Add some diesel 2. Reconnect the pipe 3. Clean the fliter net 4. Clean the eletrical ege
The pump of burner does not start to work	<ol style="list-style-type: none"> 1. The pump strip is lock 2. The setted time have finish 3. The temperature valve have reach the setted valve 4. The burner is out of fuel 	<ol style="list-style-type: none"> 1. Check and clean the pump of the burner 2. Reset the time 3. Reset the temperature 4. Check the level of fuel in the reservior
Black smoke come out after the burner open	<ol style="list-style-type: none"> 1. The open position of burner damper is not enough 2. The pressure of pump is not enough 	<ol style="list-style-type: none"> 1. Adjust the damper more to more big position 2. Reset to the standard valve
Temperature rise is slow	<ol style="list-style-type: none"> 1.The damper is not close or not closed completely 	<ol style="list-style-type: none"> 1.Closed the damper completely
The lights do not work	<ol style="list-style-type: none"> 1. The fuses have blown 2. Ballast is interrupted 3. Connection ports loose 	<ol style="list-style-type: none"> 1. Replace the light fuses 2. Replace the ballast 3. Fix the connection ports
The pressure inside the booth is higher than usual	<ol style="list-style-type: none"> 1. The motor of the exhaust ir unit is off or not working regularly. 2. The extraction duct is obstructed 	<ol style="list-style-type: none"> 1. CheckThe exhaust air unit fuses Ensure the cable is connectyed to the motor and the the locks of the control panel 2. Check the filter of the basement or the exhaust air unit and replace them if necessary.
The pressure in the booth is lower than usual	<ol style="list-style-type: none"> 1.The motor of the generator is off or does not work regularly 2.The emission duct is obstructed 	<ol style="list-style-type: none"> 1.Check the generator fuses. Ensure the cable is connected the motor and the locks of the control panel. 2.Check there are not obstacles at the mouth of emission of the intake air unit.

Appendix III : Electrical Chart(Shown in Attached File)

Appendix IV : Structrue of the Booth(Shown in Attached File)